

Wall Mount Nitrogen Generators

for Dry Pipe & Pre-Action Sprinkler Systems.

50Hz Cycle

General Air Products Wall Mount Nitrogen Generators are specifically designed to provide on-site, high purity nitrogen for use in dry and pre-action fire sprinkler systems and Utilize a simple, low-profile design ready to be connected to a new or existing system. Each Wall Mount Nitrogen Generator includes an integrated fire protection air compressor specifically designed to fill the sprinkler system to supervisory pressure within 30 minutes per NFPA 13. General Air Products Wall Mount Nitrogen Generators provide a reliable and efficient method of producing a minimum of 98% nitrogen at the point of usage which will inhibit corrosion and improve the life of the sprinkler system.

FM APPROVED



Included With Every Wall Mount Nitrogen Generator:



Fire Protection Air Compressor



38 Liter N2 Storage Tank



Portable N2 Analyzer



.76 Stainless Steel Flex Hose w/Union



Vibration Isolation Pads

Features and Benefits

- Turn-key Design for Easy Installation
- Premium Nitrogen Membrane Technology
- 98%+ Nitrogen Purity Standard
- PLC Controller for Data Recording & Simplified Operation
- Bypass & Leak Detection Alarms
- Contacts for Tie-in to Building Monitoring System
- Lifetime Customer Service & Technical Support

Maintenance Capacity (gal/L)	Model Number	Fill Capacity (gal/L)		Compressor		Electrical Specifications				N2 Tank (gal/L)	Unit Weight (lbs/kg)		
		Gallons	Liters	Type	HP/kW	Hz	Phase	Voltz	Amps		Cabinet	Horizontal Tank	Vertical Tank
1275/4826	NGP-WM300-6A	300	1135	Oil-Less	1/2 / .25	50	Single	220	3.2	10/38	135/61	50/23	40/18
3880/14687	NGP-WM600-6A	520	1968	Oil-Less	3/4 / .50	50	Single	220	6.1	10/38	155/71	50/23	40/18

* N2 storage tanks come in horizontal or vertical configurations. Specify when ordering.

*60 Hz units also available. Contact factory for details.

Note: All information is subject to change without notice. Consult factory for most up-to-date product details

WARNING: Cancer and Reproductive Harm – www.p65warnings.ca.gov

Nitrogen Generator System Accessories:

AIR MAINTENANCE DEVICE



Part # AMD-1

Required to regulate the volume of air being delivered to the sprinkler system. General Air Products Air Maintenance Devices are UL listed & FM approved.

PURGE VENT / SAMPLING PORT



Automatic Purge
NGP-APV

Provides a simple and reliable way to purge oxygen from the sprinkler system during the nitrogen fill process and monitor the nitrogen purity throughout the entire fire sprinkler system.



Manual Purge
NGP-PV-1



Wall Mount Nitrogen Generators for Dry Pipe & Pre-Action Fire Sprinkler Systems

Wall Mount Nitrogen Generator Cabinet Details

0.63mW x 0.94mH x 0.36mD

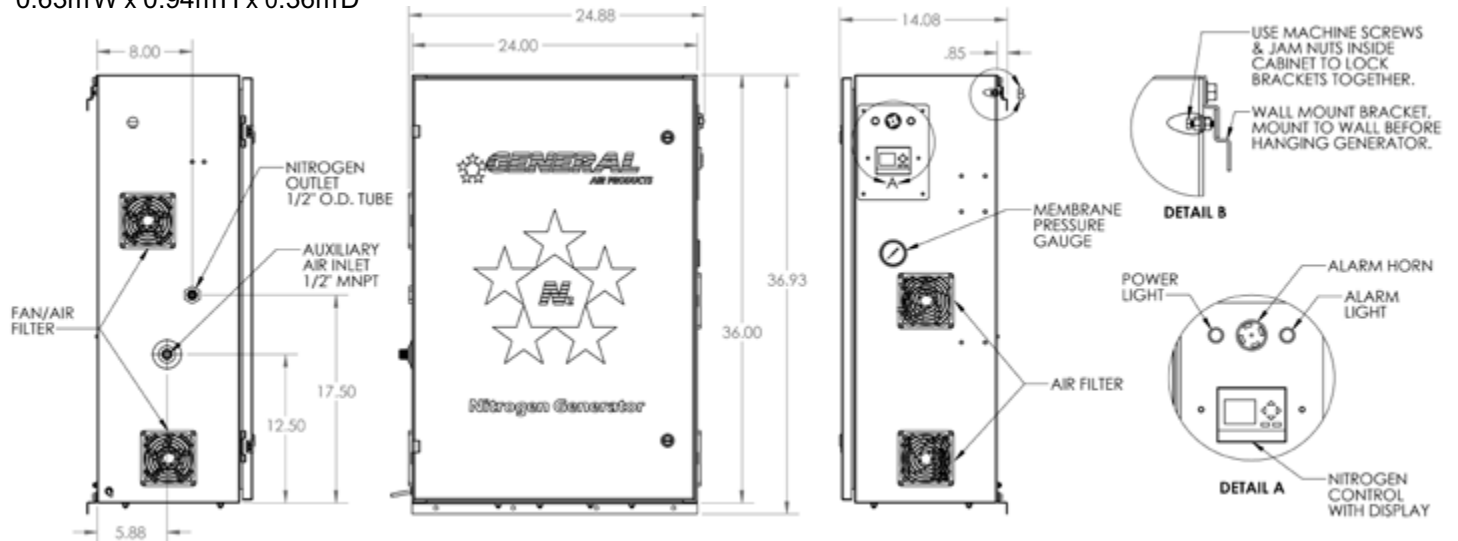

- The nitrogen generator cabinet can be mounted to a wall, floor or the horizontal N2 storage tank.

38 Liter Nitrogen Storage Tank Details (Horizontal & Vertical Tanks Available)

Horizontal Tank

0.91mW x 0.4mH x 0.34mD

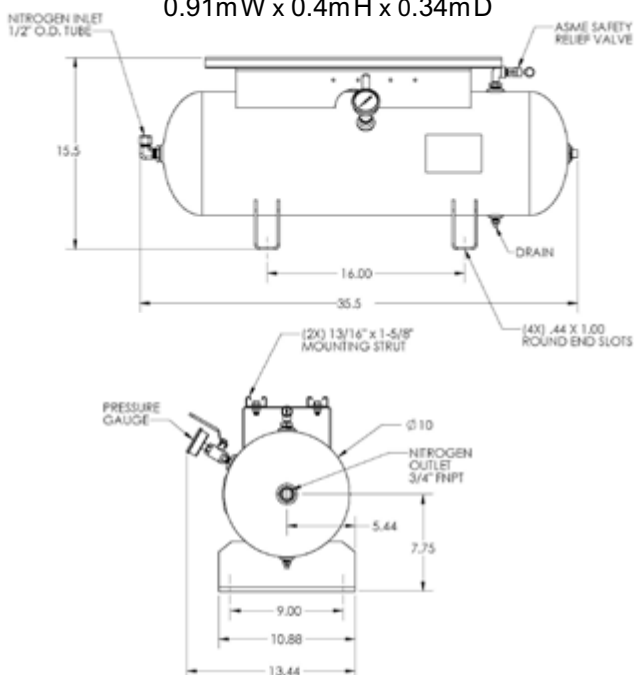

Vertical Tank

0.25mØ x 0.94mH

