



Vapor Pipe Shield™

ENGINEERED VAPOR-PHASE CORROSION INHIBITOR SYSTEMS

For Dry Pipe & Pre-Action Fire Sprinkler Systems

Installation, Operation, and Maintenance Manual

Models: VPS-500A / VPS-500A-NV / VPS-500B / VPS-500B-NV / VPS-1000A / VPS-1000A-NV / VPS-1000B / VPS-1000B-NV / VPS-1500A / VPS-1500A-NV / VPS-1500B / VPS-1500B-NV / VPS-2000A / VPS-2000A-NV / VPS-2000B / VPS-2000B-NV

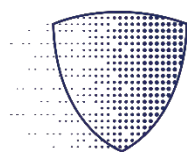
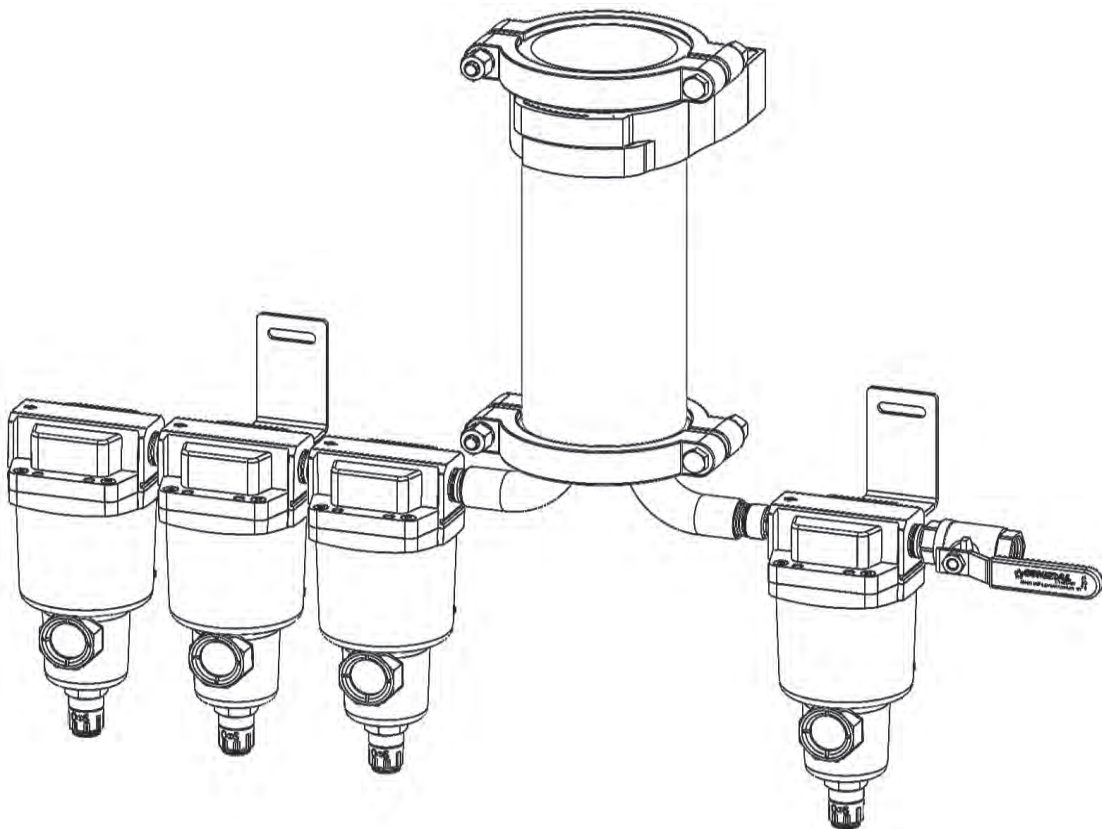

VAPOR
Pipe Shield

Technical Assistance:
800-345-8207

Additional Product Information:
generalairproducts.com

Version 1.20
Dec-2024

TABLE OF CONTENTS

1	Safety Guidelines & Disclosures.....	3
2	Overview	4
3	Installation	5
3.1	Location	5
3.2	Mounting.....	6
3.2.1	Wall Mounting (STANDARD).....	6
3.2.2	Floor Mounting (OPTIONAL / SOLD SEPARATELY).....	9
3.2.3	Riser Mounting (OPTIONAL / SOLD SEPARATELY).....	11
3.3	Flow Reversal (Field Retrofit).....	13
3.4	Filtration / Module Remoting.....	14
3.5	Inlet Connections	15
3.6	Outlet Connections	15
3.7	Drain Connections	16
3.8	VPS Vapor Indicator Test-Port.....	17
3.9	Material Compatibility	18
3.10	Illustrative Layout	18
4	Start-Up Instructions	19
5	Operation.....	21
5.1	Initial Filtration (Pre-filters).....	21
5.2	Proprietary Air Treatment (Module(s) & Cartridge(s))	21
5.3	Post Filtration (After-filter)	21
5.4	Protection Dispersal Through the Dry-Pipe Sprinkler System	21
6	Maintenance Schedule	22
6.1	Standard Maintenance Procedure (annual).....	22
7	Troubleshooting.....	27
8	General Arrangements.....	28
8.1	Sample System Layout	28
8.2	Feature Layout.....	28
8.3	Maintenance Schedule Connections.....	29
8.4	Module/ Cartridge Arrangement	30
8.5	General Arrangement.....	30
9	Warranty Policy	31

I SAFETY GUIDELINES & DISCLOSURES

This manual contains information that is very important to know and understand. This information is provided for SAFETY and to PREVENT EQUIPMENT PROBLEMS. To help recognize this information, observe the following symbols.



Danger indicates an imminently hazardous situation which, if not avoided, WILL result in death or serious injury.



Warning indicates a potentially hazardous situation which, if not avoided COULD result in death or serious injury.



Caution indicates a potentially hazardous situation which, if not avoided, MAY result in minor or moderate injury.

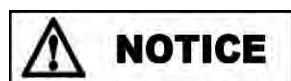

Notice indicates important information, that if not followed may cause damage to equipment

Vapor Pipe Shield (VPS) does not require any special handling or PPE during installation, operation, or maintenance activities; however, washing your hands after handling VPS components as a standard sanitary precaution is recommended. The use of VPS shall be in conformance with all applicable health and environmental regulations for the location where it is installed. In the event of sprinkler head activation, exit the building per standard fire procedures for the building in accordance with state and local guidelines. The active corrosion inhibitor in this product is classified as an article by OSHA (USA, Canada, EU), and therefore, an SDS sheet is not required by OSHA or other health agencies. To request an SDS for the inhibitor in large-volume/industrial-bulk supply (e.g., drums or other industrial quantities) and for any environmental, health, or safety inquiries, please contact General Air Products via the contact information provided in this manual.

VPS (when properly sized) is intended to provide corrosion protection for a Dry or Pre-Action Fire-Sprinkler System for one year. The inhibitor cartridge should be replaced annually to extend protection for an additional year of protection. Each VPS unit (when properly sized) is rated for use with up to four fire sprinkler systems. Multiple risers connected to a single VPS module should not exceed four independent risers with a total gallon capacity not exceeding the Maintenance Capacity listed in the table below. Using a VPS unit on more than four systems may void the manufacturer's warranty. VPS is compatible with all types of NFPA 13, 14, and 25 dry and pre-action fire sprinkler systems. VPS is not compatible with a deluge system. For compatibility with other types of fire sprinkler systems, contact General Air Products via the contact information provided in this manual.

VPS is intended for use where the ambient conditions of the sprinkler piping range between -40°F and 150°F. The VPS module itself must be installed in an ambient temperature between +40°F and 150°F. Contaminants or other foreign materials within a sprinkler system may adversely impact the properties and performance of the vapor corrosion inhibitor. The functional life of VPS may be impacted by the end-use environmental conditions. Systems using VPS are to be inspected, tested, and maintained in accordance with the manufacturer's instructions and NFPA 25. Any air compressor(s) in use with VPS must utilize a pressure relief valve on or adjacent to the compressor, and the pressure-relief set pressure must be less than the pressure rating of the VPS unit. Sprinkler system fill time must be checked for compliance with NFPA standards after installation.

IMPORTANT: ALL INFORMATION SUBJECT TO CHANGE WITHOUT NOTICE.
Consult factory for the most up to date version of this manual - 1-800-345-8207.

Call 1-800-345-8207

or visit our web site for our complete product listing

www.GeneralAirProducts.com

2 OVERVIEW

Vapor Pipe Shield (VPS) was created to be an economical & scalable option to protect various sizes of dry-pipe sprinkler systems, and is easily upgradable to handle later-date expansions of existing systems. Sizing and capacity information for VPS variants are displayed in the table below.

Model Number †	System Capacity *	Total Maintenance Capacity	Installed Cartridges	Overall Dimensions (L x W x H)	Approximate Weight
VPS-500A VPS-500A-NV VPS-500B VPS-500B-NV	500 Gallon	2,000 Gallon	1	6.5" x 28.75" x 20.25" 6.5" x 28.75" x 21.5"	20 Lbs.
VPS-1000A VPS-1000A-NV VPS-1000B VPS-1000B-NV	1,000 Gallon	4,000 Gallon	2	6.5" x 28.75" x 28.25" 6.5" x 28.75" x 29.5"	26 Lbs.
VPS-1500A VPS-1500A-NV VPS-1500B VPS-1500B-NV	1,500 Gallon	6,000 Gallon	3	6.5" x 28.75" x 36.25" 6.5" x 28.75" x 37.5"	32 Lbs.
VPS-2000A VPS-2000A-NV VPS-2000B VPS-2000B-NV	2,000 Gallon	8,000 Gallon	4	6.5" x 28.75" x 44.25" 6.5" x 28.75" x 45.5"	38 Lbs.

* System capacity is +/- 10% due to site location and conditions.

† For all NV models only – UL Listed isolation valve is required to be installed between the VPS discharge and the dry pipe network.

VPS is positioned after both the Air Source (air compressor) (sold separately) & Check Valve (immediately off the air source) (optional & sold separately), but before any Air Maintenance Device (sold separately) if one or more is installed. Air from the air source enters the VPS unit and goes through the 3-phase process described below.



Following the air treatment, corrosion protection infused air exits the VPS unit and is directed into an Air Maintenance Device (AMD) or directly into the piping system if an AMD is not utilized, and from there into the dry-pipe sprinkler system to be protected. Purging the dry-pipe sprinkler system of air is not required or suggested; however, if a purge valve (sold separately) is used, you must follow the separate Purge Valve OIM instructions on purging procedures. A simplified representation of VPS installed on a system is shown below.

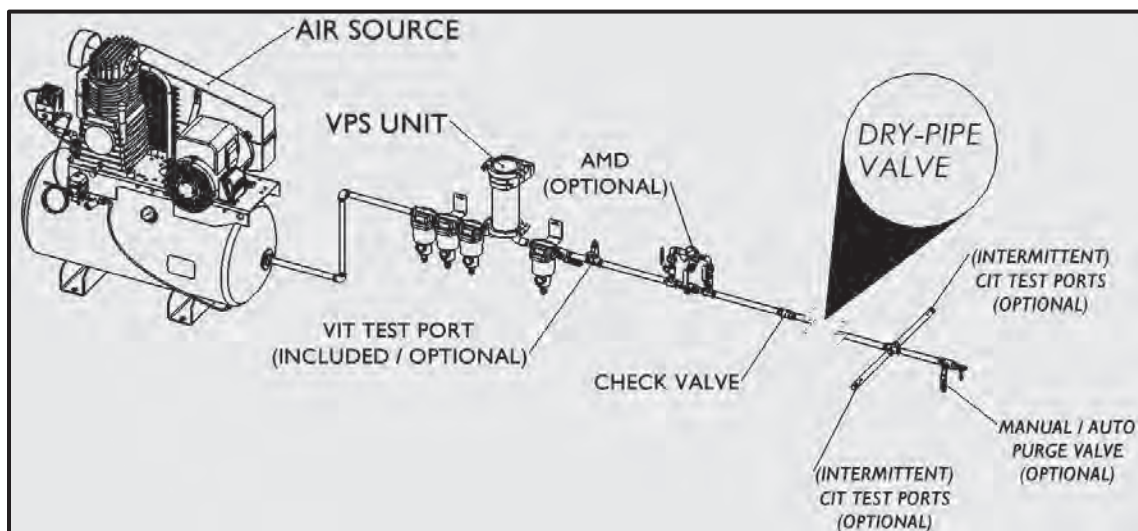

Vapor Pipe Shield is intended for the exclusive use with properly sized General Air Products' Fire-Protection Air Compressors. Use with alternative equipment may not have been verified by the Manufacturer and may void Manufacturer's Warranty.

3 INSTALLATION

3.1 LOCATION

Install the Vapor Pipe Shield (VPS) unit in a clean, dry location; with ambient temperatures between 40° F (4.5° C) and 150° F (65.5° C) at all times; adjacent to the system piping.

When installing, be sure to allow ample room to access and maintain all forward-facing components, namely the Filters (to change the filter elements) and the Module(s) (to change Cartridge(s)). It is recommended that a minimum of **3 inches clearance off the left & right**, and **6 inches clearance off the top & bottom** be provided for the VPS unit. Recommended minimum clearances are shown below.

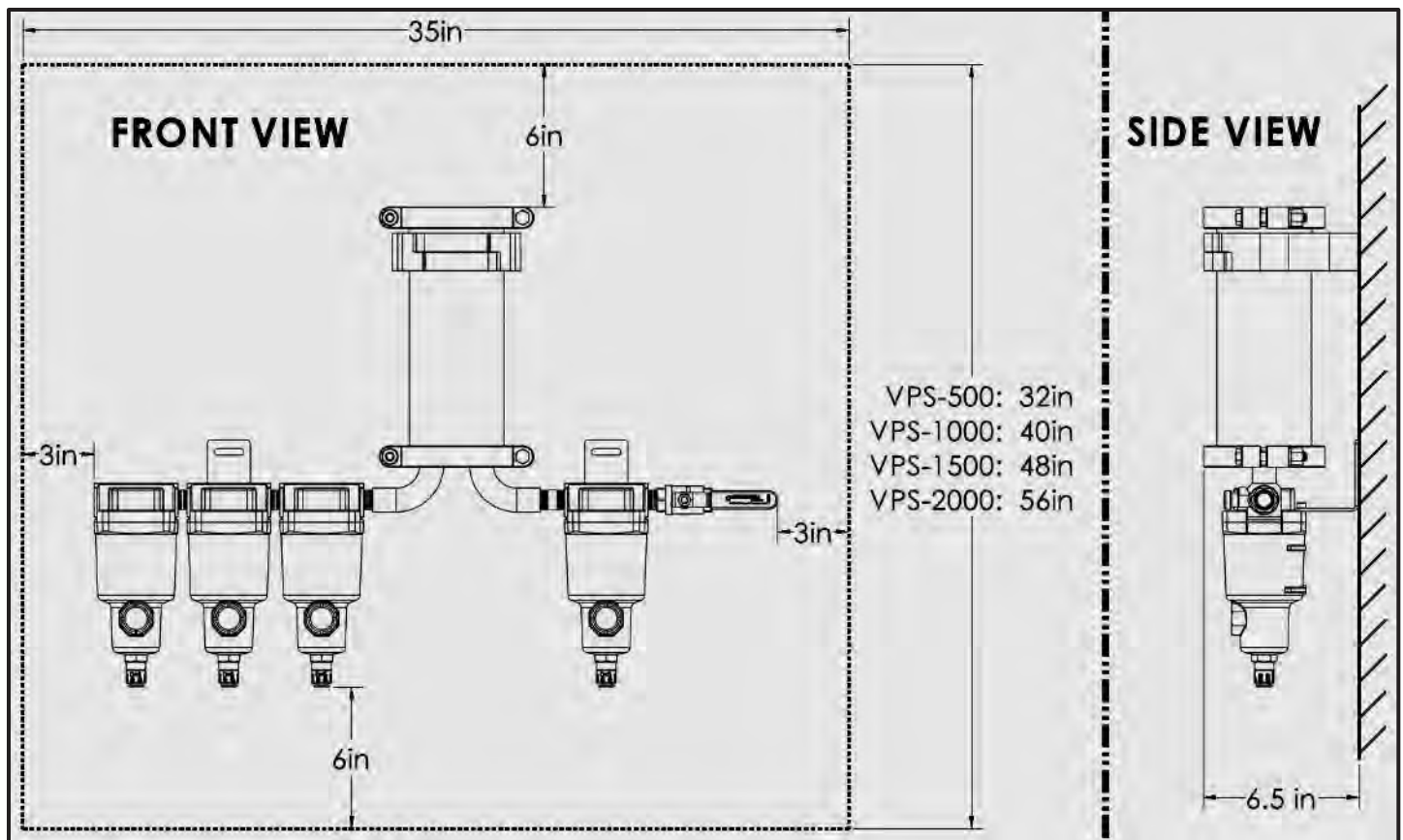

The unit must be connected in-line with the dry-pipe sprinkler system. The main module unit must be mounted vertically as shown above, so that all Drain Ports are facing down. Additional space below the VPS unit for collection containers may be required, in addition to the 6" clearance from the bottom of the unit.



NOTICE

If the location is subject to excessive humidity, additional water removal devices may be necessary to install between the air source/ air storage tank and the VPS unit. For more information and/ or options for water removal, contact General Air Products Technical Assistance at (800) 345-8207.



WARNING

If the mounting location is below freezing at any time, the system may be damaged which **COULD** result in death or serious injury. All components under pressure must be inspected immediately before use.

The unit must be positioned after both the Air Source (air compressor) (sold separately) & Check Valve (immediately off the air source) (optional & sold separately), but before any Air Maintenance Device (sold separately). It is recommended to install an isolatable bypass around the unit for more convenient maintenance. Do **NOT** flood the VPS unit with water. Flooding the unit will require **ALL** cartridges to be replaced. While the VPS unit is designed to operate as a standalone corrosion mitigation device, the unit may also be used in conjunction with other types of corrosion mitigation equipment, such as but not limited to: Dryers, Nitrogen Generators, etc.; confirm suitability with your manufacturer. In such a case(s), the unit should be installed after such equipment, and a Shutoff Valve (sold separately) is strongly recommended to be placed before the VPS unit.

Contact General Air Products Technical Assistance at (800) 345-8207 for assistance as needed.



NOTICE

If the VPS unit is to be placed before the other corrosion mitigation equipment, contact the corrosion mitigation equipment's manufacturer first to confirm such positioning is compatible with their unit.



WARNING

Do not puncture the VPS unit; or attempt to install, service, or change a Cartridge; or attempt to loosen any fittings on the VPS unit while under pressure. Doing so **COULD** result in death or serious injury. All components under pressure must be inspected before use.

3.2 MOUNTING

3.2.1 Wall Mounting (STANDARD)

Mount the VPS unit to a wall or stable structure using $\frac{1}{4}$ inch hardware (not included) that is appropriate for the mounting surface. The upper mounting clamp (located on the top-most Module) and the two main brackets (located on the second & last filter) are used to support the VPS unit. Do not clamp over or mount on the filter bowls, as they will need to be accessed during maintenance periods. Acceptable mounting locations on the VPS unit are displayed below.

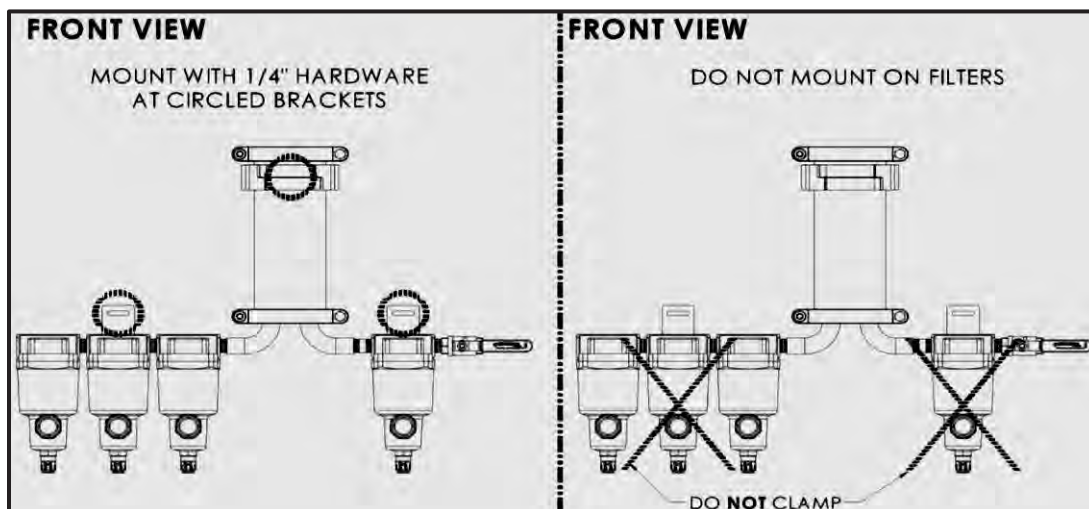



While the VPS unit creates no vibration, failure to properly secure the unit, in a location free from impact risk, may result in damage to the system, unit, or personnel. All workmanship and materials (such as pipe and fittings) must comply with the guidelines set forth in NFPA 13.

1) Mount Upper Clamp.

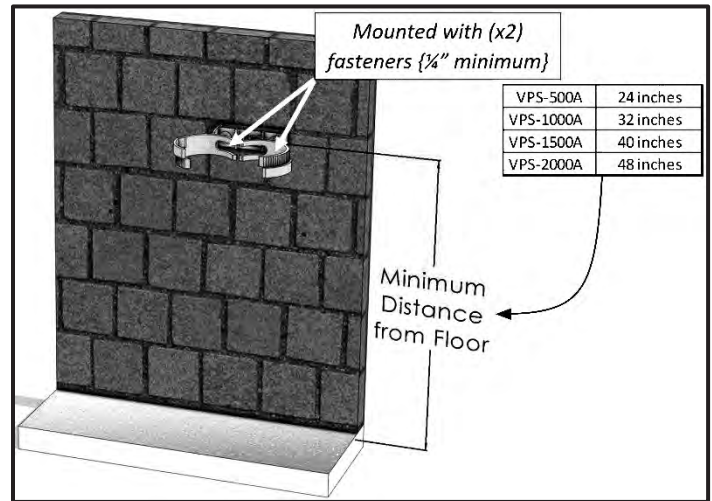

- 2) Push the top-most Module of the VPS unit into the Upper Clamp as shown. The jaws of the Upper Clamp should lock completely over the top-most Module. Note, the top-most Module will rest loosely inside the Upper Clamp.

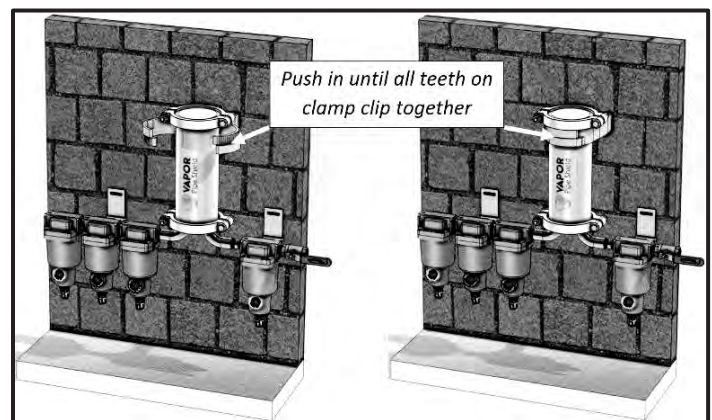

- 3) Lift the VPS unit slightly so that the weight is off the Upper Clamp. Then mount the Mounting Brackets.

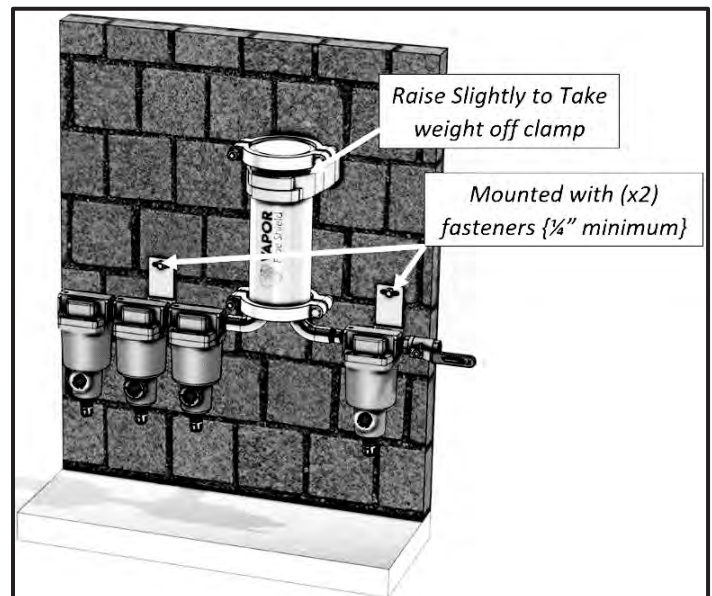

CAUTION

Failure to secure all equipment as described may result in damage to the system, unit, or personnel.



NOTICE

Additional measures may be required to safely secure and mount the VPS Unit depending on each situation.

3.2.2 Floor Mounting (OPTIONAL / SOLD SEPARATELY)

Secure the VPS unit to the floor using appropriate mounting hardware through the **(x4) 7/16 inch holes** provided, hardware not included. The holes follow a **6.5 inch x 21 inch rectangular bolt pattern**. Always use hardware that is suitable for the floor material to ensure stability.

For added security, if the unit is positioned against a wall, the upper mounting clamp (located on the top-most Module) can be utilized to tie the module(s) to the wall; this is optional and based on user preference. Avoid restricting access to any maintenance-required components when choosing your mounting location.



CAUTION

While the VPS unit creates no vibration, failure to properly secure the unit, in a location free from impact risk, may result in damage to the system, unit, or personnel.

- 1) Remove the Mounting Brackets by removing the screws (2 each) located on the top of each filter using a **5mm hex key**. Save the screws for reuse on the Floor Mounting Brackets. See adjacent figure.

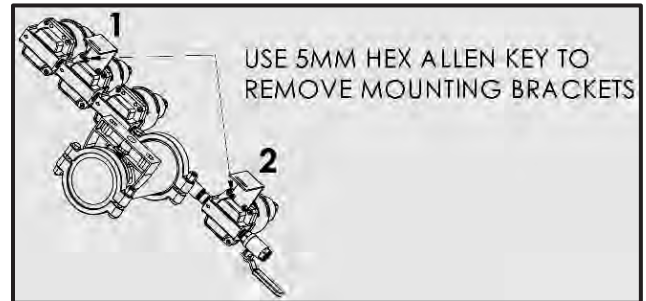

- 2) Install the Floor Mounting Brackets on the mounting holes provided on the filters as shown using the same screws (2 each), using a **5mm hex key**. Use Thread Locker on the screws. See adjacent figure.

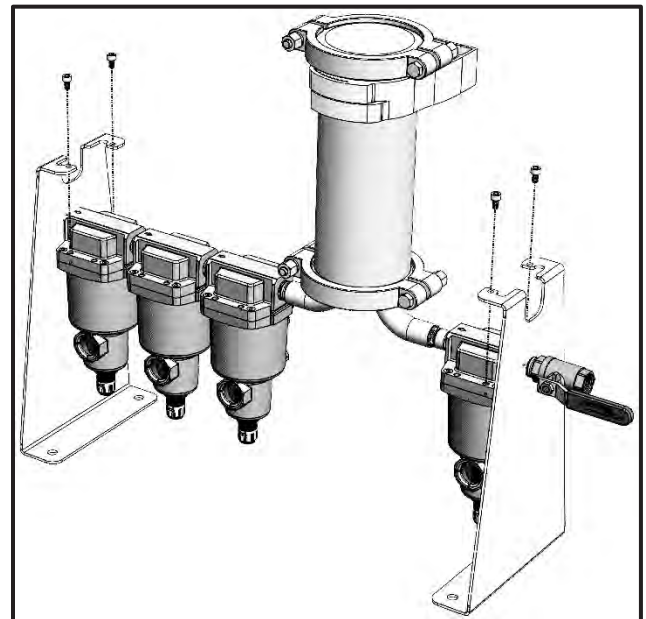

- 3) Position the VPS unit in a suitable location meeting the requirement described above. The footprint of the unit is 23.5 inches x 8 inches, while the height varies depending on the unit size. The use of the upper mounting clamp is optional as described above. See adjacent figures.

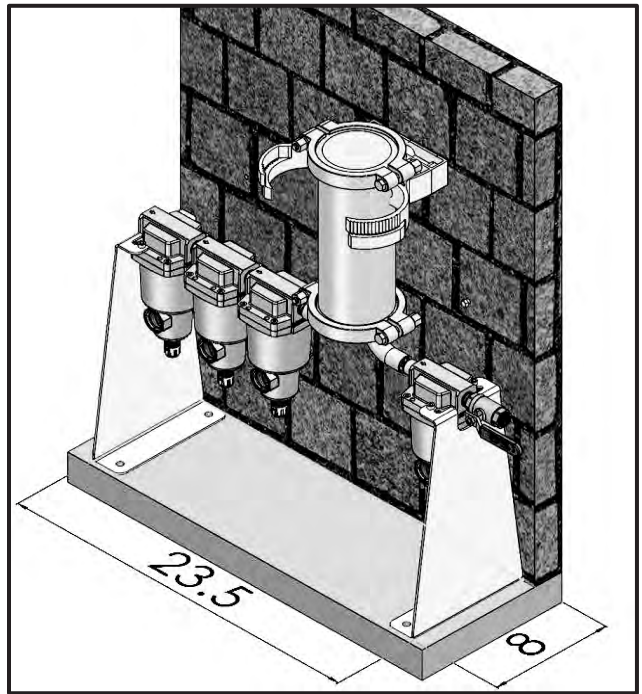
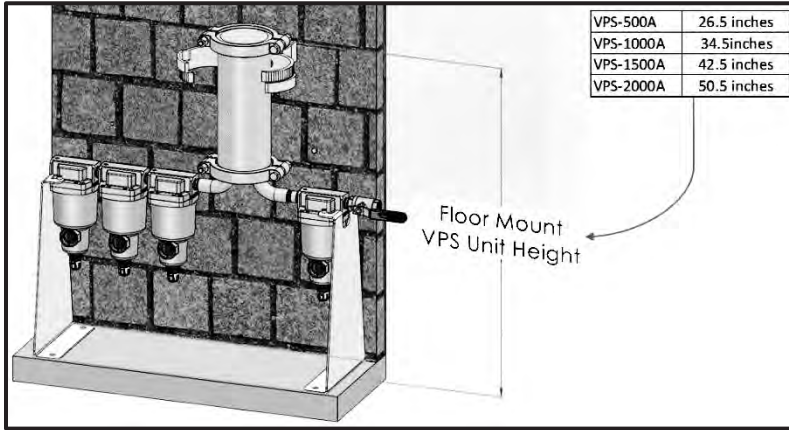

- 4) Secure the VPS unit to the floor using appropriate mounting hardware through the **(x4) 7/16 inch holes** provided, hardware not included. The holes follow a **6.5 inch x 21 inch rectangular bolt pattern**. Always use hardware that is suitable for the floor material to ensure stability.

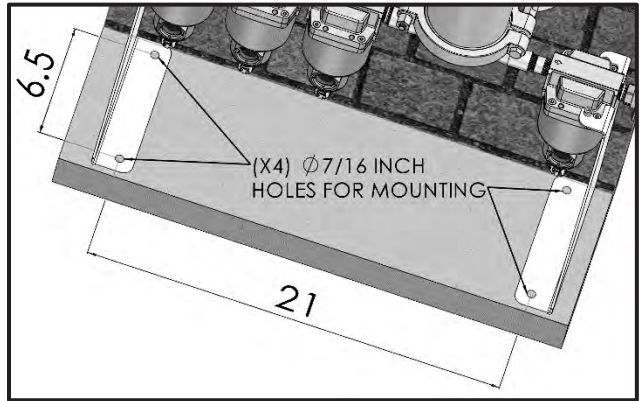

CAUTION

Failure to secure all equipment as described may result in damage to the system, unit, or personnel.



NOTICE

Additional measures may be required to safely secure and mount the VPS Unit depending on each situation.

3.2.3 Riser Mounting (OPTIONAL / SOLD SEPARATELY)

Install the VPS unit on a vertical riser using the provided worm drive clamps. The unit must be mounted upright to ensure proper functionality and safety. Ensure the chosen riser location is stable and free from any risks of impact or disturbance.



While the VPS unit creates no vibration, failure to properly secure the unit, in a location free from impact risk, may result in damage to the system, unit, or personnel.

- 1) Remove the Upper Mounting Clamp from the VPS unit and install it onto the VPS Riser Mounting Plate as shown. A Hex Key for the screw is provided.

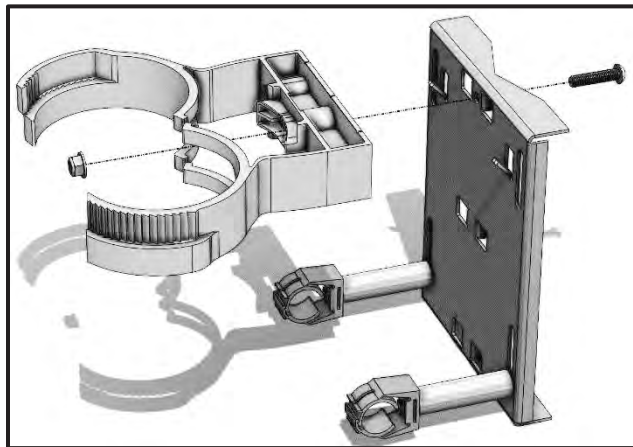

- 2) Install the VPS Riser Mounting plate onto the riser using the provided worm drive clamps. Ensure sufficient space is available prior to mounting the VPS unit.

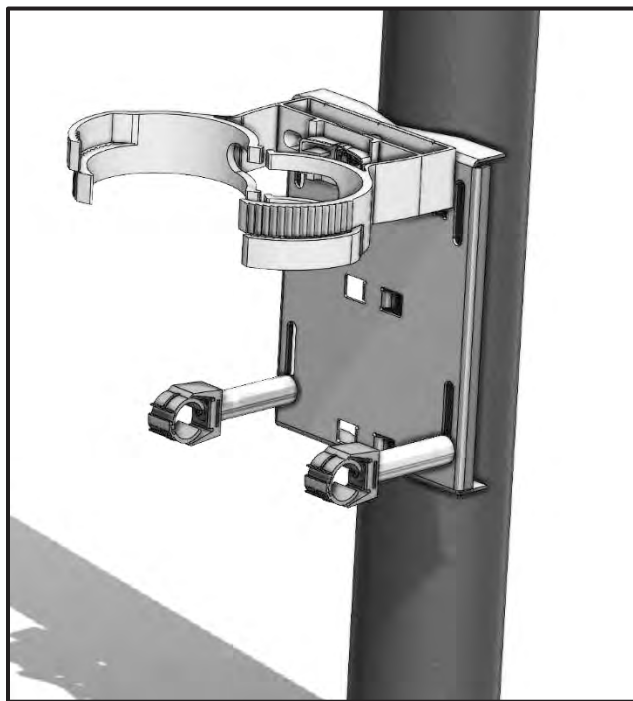

Model Number †	Overall Dimensions (L x W x H)	Approximate Weight
VPS-500A VPS-500A-NV	6.5" x 28.75" x 20.25"	20 Lbs.
VPS-500B VPS-500B-NV	6.5" x 28.75" x 21.5"	
VPS-1000A VPS-1000A-NV	6.5" x 28.75" x 28.25"	26 Lbs.
VPS-1000B VPS-1000B-NV	6.5" x 28.75" x 29.5"	
VPS-1500A VPS-1500A-NV	6.5" x 28.75" x 36.25"	32 Lbs.
VPS-1500A VPS-1500A-NV	6.5" x 28.75" x 37.5"	
VPS-2000A VPS-2000A-NV	6.5" x 28.75" x 44.25"	38 Lbs.
VPS-2000A VPS-2000A-NV	6.5" x 28.75" x 45.5"	

- 3) Open all three Mounting Clamps, then install the VPS Unit as shown. Ensure all clamps are fully secured.

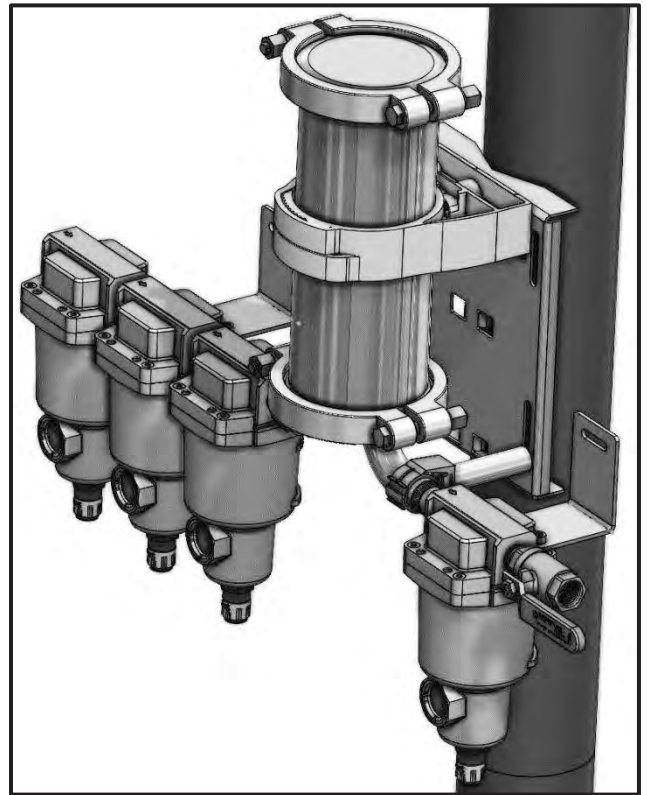
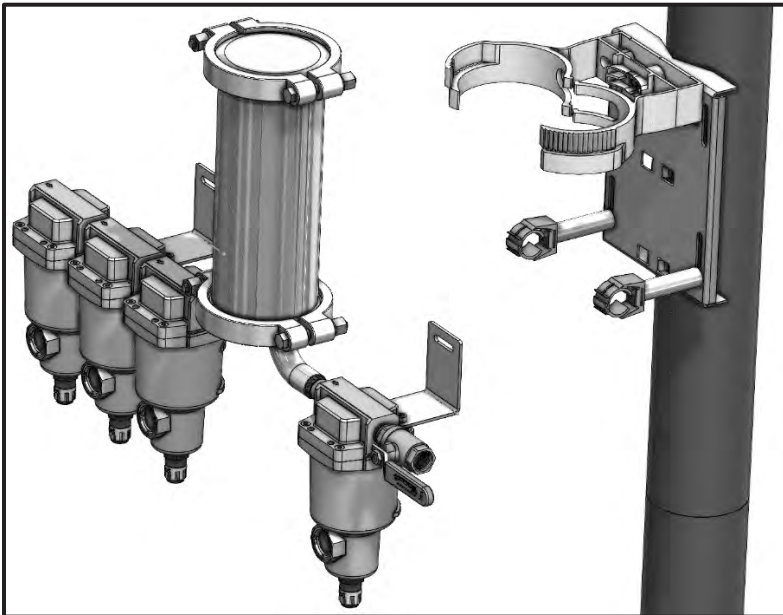

CAUTION

Failure to secure all equipment as described may result in damage to the system, unit, or personnel.



NOTICE

Additional measures may be required to safely secure and mount the VPS Unit depending on each situation.

3.3 FLOW REVERSAL (FIELD RETROFIT)

The Vapor Pipe Shield (VPS) unit can have its flow reversed by completing the following steps. If already installed, always uninstall the VPS unit prior to any field retrofit work. The standard configuration is shown in the adjacent figure. Filters shown may appear differently than actual filters used. All filters should be maintained and operated according to the maintenance schedule and procedures within this manual.



By modifying the VPS system from its original factory configuration, you assume all responsibility for any resultant damage or malfunctions. All workmanship and materials (such as pipe and fittings) must comply with the guidelines set forth in NFPA 13. General Air holds no liability for any modifications or alterations made to the VPS system after it leaves the factory. Ensure you understand the guidelines provided and consult with the technical support team for any clarifications.



- 1) Remove the Filter Bowls by removing the screws (4 each) located on the top of each filter using a **4mm hex key**; and remove the Mounting Brackets by removing the screws (2 each) located on the top of each filter using a **5mm hex key**. See adjacent figures.

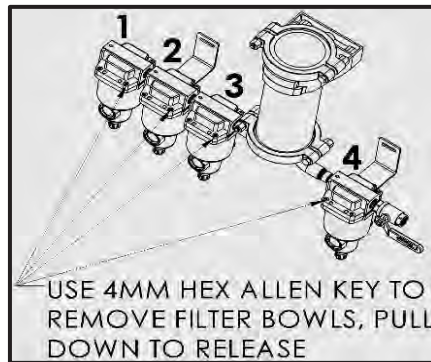
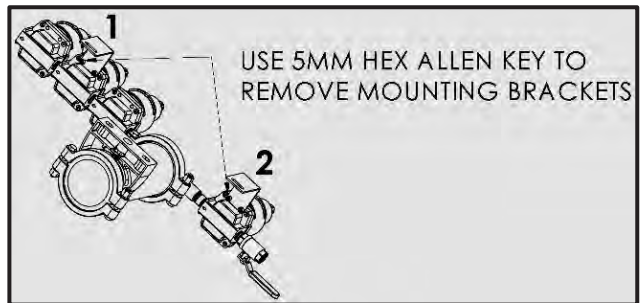
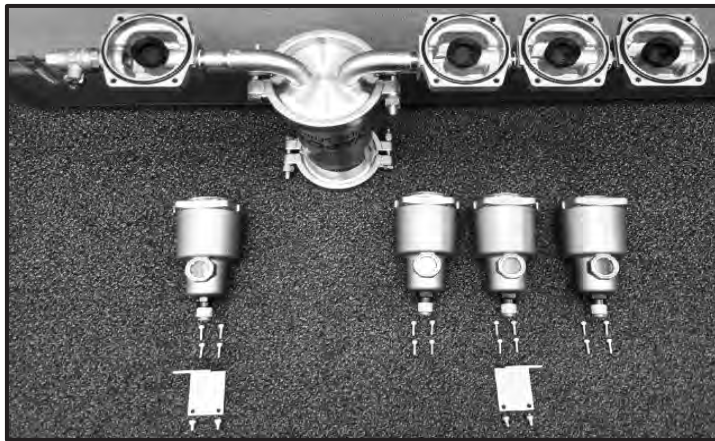

- 2) Rotate the Filter Bowls 180° and reinstall them using their respective mounting screws (4 each), using a **4mm hex key**; and reinstall the Mounting Brackets on the opposite set of mounting holes on the same filters using their respective screws (2 each), using a **5mm hex key**. Use Thread Locker on the mounting bracket screws only. Ensure all O-rings / Gaskets are in place, prior to reassembling. See adjacent figure.



For more information, contact General Air Products Technical Assistance at (800) 345-8207 for assistance as needed.

3.4 FILTRATION / MODULE REMOTING

The VPS system was designed with flexibility in mind to accommodate installations where space is a constraint. This adaptability means certain components of the VPS unit can be remotely positioned, allowing for more versatile placement within various building environments.



By modifying the VPS system from its original factory configuration, you assume all responsibility for any resultant damage or malfunctions. All workmanship and materials (such as pipe and fittings) must comply with the guidelines set forth in NFPA 13. For all NV Models only, a UL Listed isolation valve is required to be installed between the VPS discharge and the dry pipe network. General Air holds no liability for any modifications or alterations made to the VPS system after it leaves the factory. Ensure you understand the guidelines provided and consult with the technical support team for any clarifications.

MODULAR ASSEMBLIES

The VPS unit comprises three core modular assemblies:

1. Prefilters
2. VPS Module
3. After-filter with Ball Valve (*Ball Valve not included in -NV variants*)

Each of these core modular assemblies can be adjusted or positioned at different angles relative to one another, provided they maintain their primary connection and meet the key considerations described below.

KEY CONSIDERATIONS

- ✓ **Orientation:** All components must be maintained in an upright orientation throughout any adjustments or repositioning.
- ✓ **Drainage and Positioning:** It's crucial that the VPS module is never positioned as the lowest point in the "VPS sub-system". This prevents any water accumulation within the module. Instead, water should be directed to freely drain through the filter drains. This means the prefilters and the after-filter with ball valve assemblies must always be lower than the VPS module to facilitate drainage.

POTENTIAL CONFIGURATIONS

1. The unit can be adjusted such that the "prefilters" are positioned at a 90° angle relative to the rest of the unit.
2. Another configuration has the "prefilters" and the "after filter with ball valve" assemblies situated away from the "VPS module." While adding bends is permissible, always ensure the VPS module does not act as a water collection point.
3. A setup can have the "VPS module" mounted on a riser plate. In this configuration, the filters can be envisioned as being positioned remotely or curved back with a 90° bend, potentially creating a U-shape that wraps around the riser or any other suitable arrangement. A riser mounting kit is available for use .

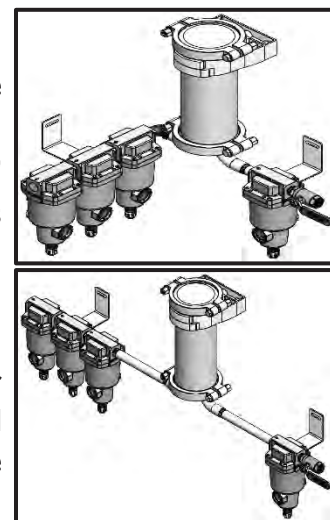

For more information, contact General Air Products Technical Assistance at (800) 345-8207 for assistance as needed.

3.5 INLET CONNECTIONS

The VPS inlet includes a water removal filter, followed by 2 coalescing filters, mounted in series on the lower corner of the unit. The inlet of the first filter is to be connected to the air source/ air storage tank. It's strongly recommended that a **Shutoff Valve (sold separately)** be positioned directly before the VPS unit (between the air source/ air storage tank and the VPS unit). See arrangement below. The inlet connection is ½” **FNPT**. Filters shown may appear differently than actual filters used. All filters should be maintained and operated according to the maintenance schedule and procedures within this manual.

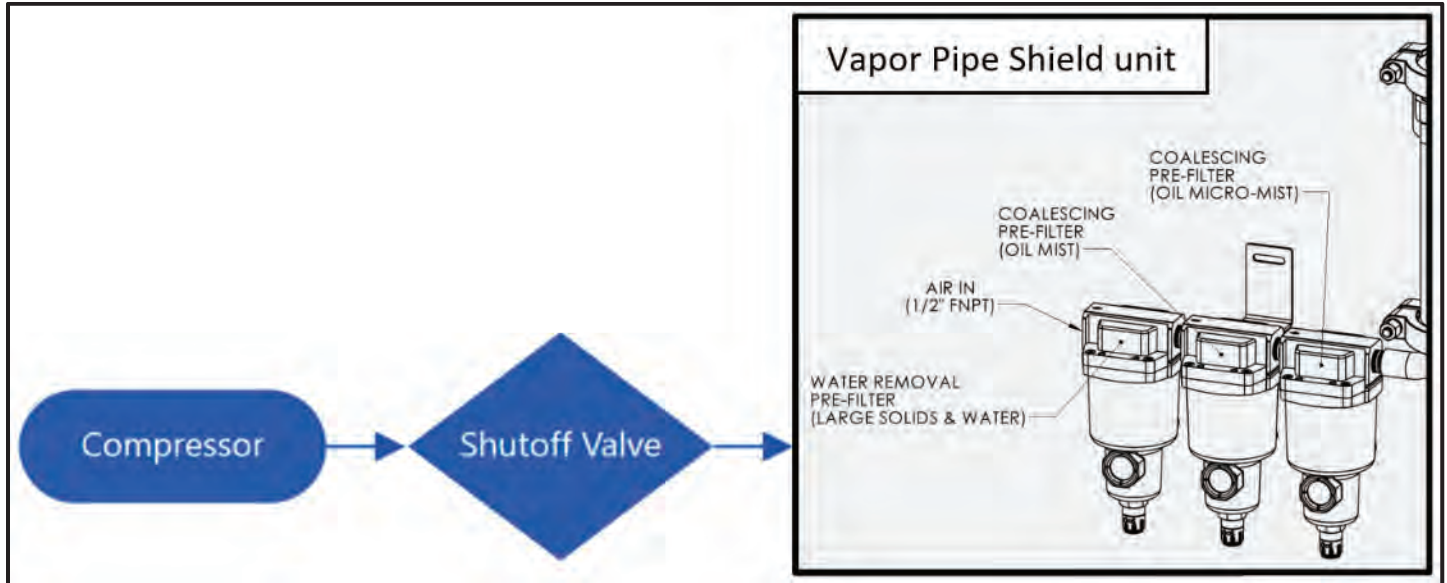

3.6 OUTLET CONNECTIONS

The VPS outlet includes a water removal filter, mounted on the lower corner of the unit, opposite from the inlet filters. The outlet of this filter is connected to a Shutoff Valve. This valve should be connected to the Air Maintenance Device (sold separately) or directly to the dry-pipe sprinkler system to be protected. See arrangement below. The outlet connection is ½” **FNPT**. Filters shown may appear differently than actual filters used. All filters should be maintained and operated according to the maintenance schedule and procedures within this manual.

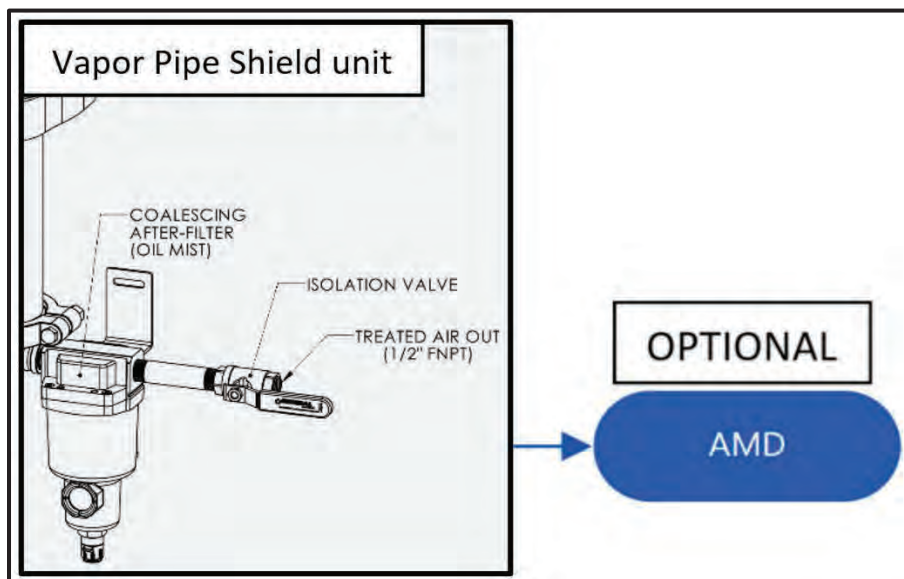

3.7 DRAIN CONNECTIONS

The VPS unit incorporates a built-in auto drain on each filter. These auto drains utilize **3/8" push to connect** tube fittings, which are available for routing the drains to a desired location. A coil of 3/8" tubing is provided to connect to each Drain Port. Routing should be done vertically down from the unit. Avoid having horizontal or uphill sections in the drain-lines, as dirt or debris could become lodged, which may in turn cause blockage in the tubing. Filters shown may appear differently than actual filters used. All filters should be maintained and operated according to the maintenance schedule and procedures within this manual. See arrangement below.

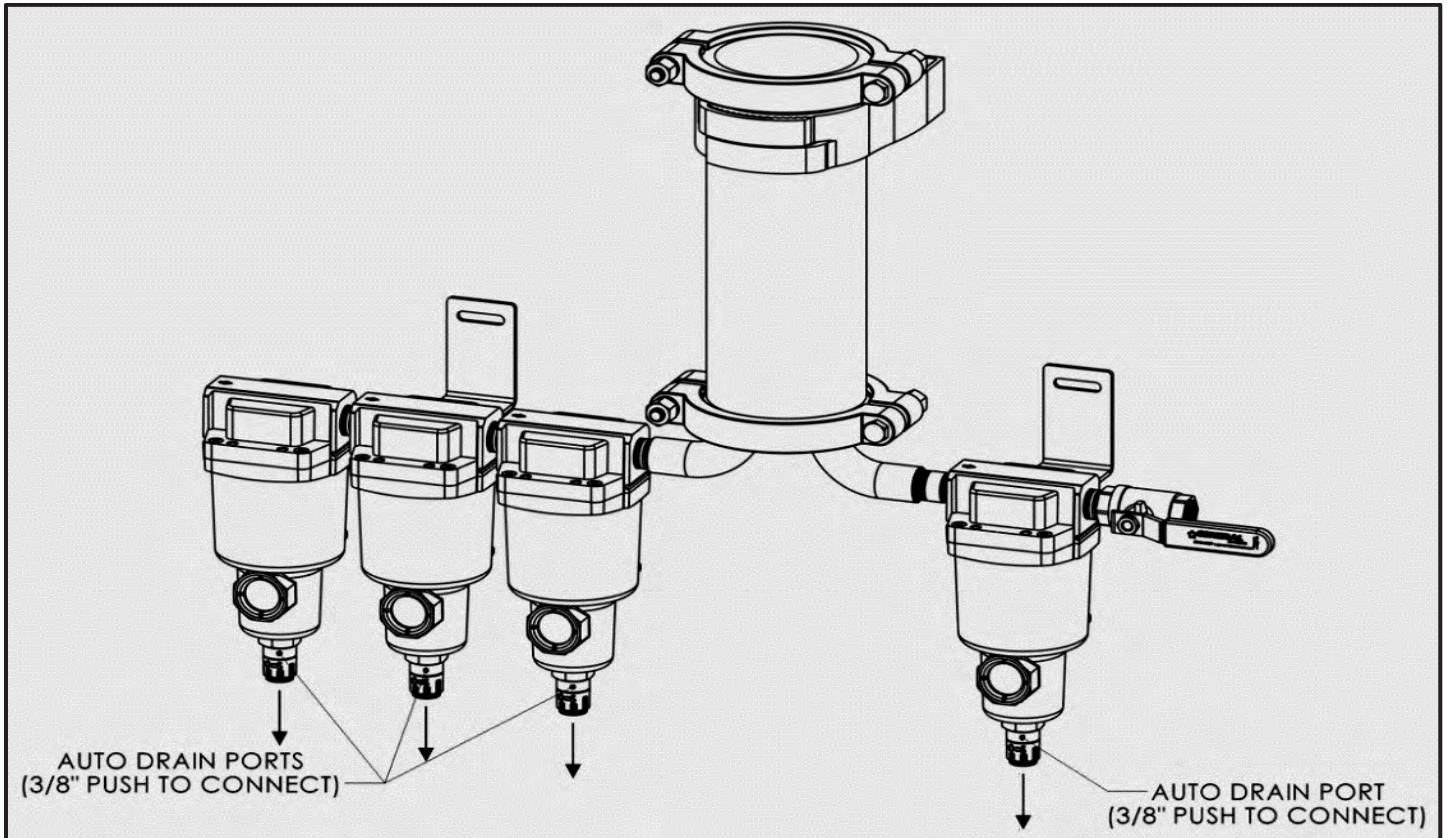

3.8 VPS VAPOR INDICATOR TEST-PORT

A VPS Vapor Indicator Test-Port (VIT) (included & optional) may be installed directly after the VPS unit and before the AMD, if desired. Also included are a set of Replaceable Indicator Cartridges (RIC) (included & optional) which may also be used if desired on the VIT. Further details described below.

RIC VAPOR DETECTOR USER GUIDE

- 1) Flick the RIC several times until the liquid remixes to a **complete blue**, as shown.

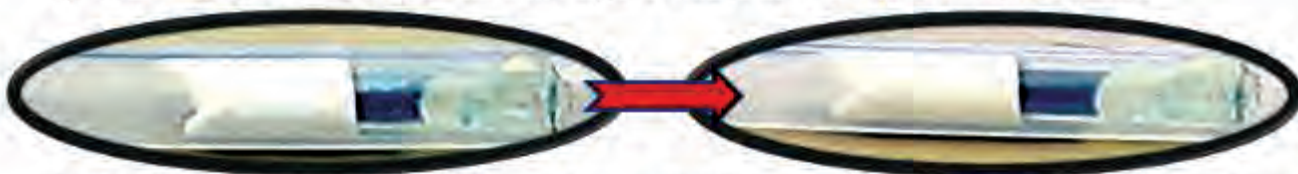

- 2) While slowly rotating the RIC, use pliers to **lightly squeeze** only the **white-strip portion** of the RIC. **Slowly increase pressure** with each consecutive squeeze, until the **white strip portion** is **significantly blue**, as shown.



- 3) Insert the RIC into the VIT (Test-Port). Then open the VIT and allow for up to 20 minutes to witness a color change.
- ❖ If any **Red** appears (does not have to be fully red), the presence of **V_pCI is indicated**.
 - ❖ If **No** red appears, then the current levels of **V_pCI may not yet be high enough** to trigger a positive test. Continuing to purge and then retesting at a later time may be advised.



- 4) Close the VIT, and plug the VIT with the 1/4" push to connect plug provided. Then remove and dispose of the RIC by conventional means in accordance with your state & local guidelines.



CAUTION

Small amounts of dust or moisture from the system may vent from the VIT and RIC; always keep eyes, mouth, & nose away from VIT and RIC when operating. Always use gloves and eye protection when operating the VIT and RIC.



NOTICE

If the RIC becomes flooded or significant water, dust, or debris saturates the RIC while in use, results may be invalidated. It is recommended to use a new RIC should this occur. Depending on your system, testing the VIT port by opening it slightly to check for water, dust, or debris, prior to using a RIC may be advisable.

3.9 MATERIAL COMPATIBILITY

The following materials have undergone testing to confirm compatibility with the Vapor Pipe Shield Product. Materials not shown may not have been verified by the manufacturer and may void warranty.

Contact General Air Products Technical Assistance at (800) 345-8207 for more information in regard to material compatibility.

Metals	Elastomers	Polymers
<ul style="list-style-type: none">•Brass•Bronze•Copper•Cast Iron•Steel•Black Steel•Stainless Steel	<ul style="list-style-type: none">•Butyl Rubber•EPDM•Natural Rubber•Nitril Rubber (BUNA-N)•Silicone•Styrene-Butadiene Rubber (SBR)	<ul style="list-style-type: none">•PTFE (Teflon)•Glass-Filled Nylon

3.10 ILLUSTRATIVE LAYOUT

The basic setup of the VPS unit is displayed below.

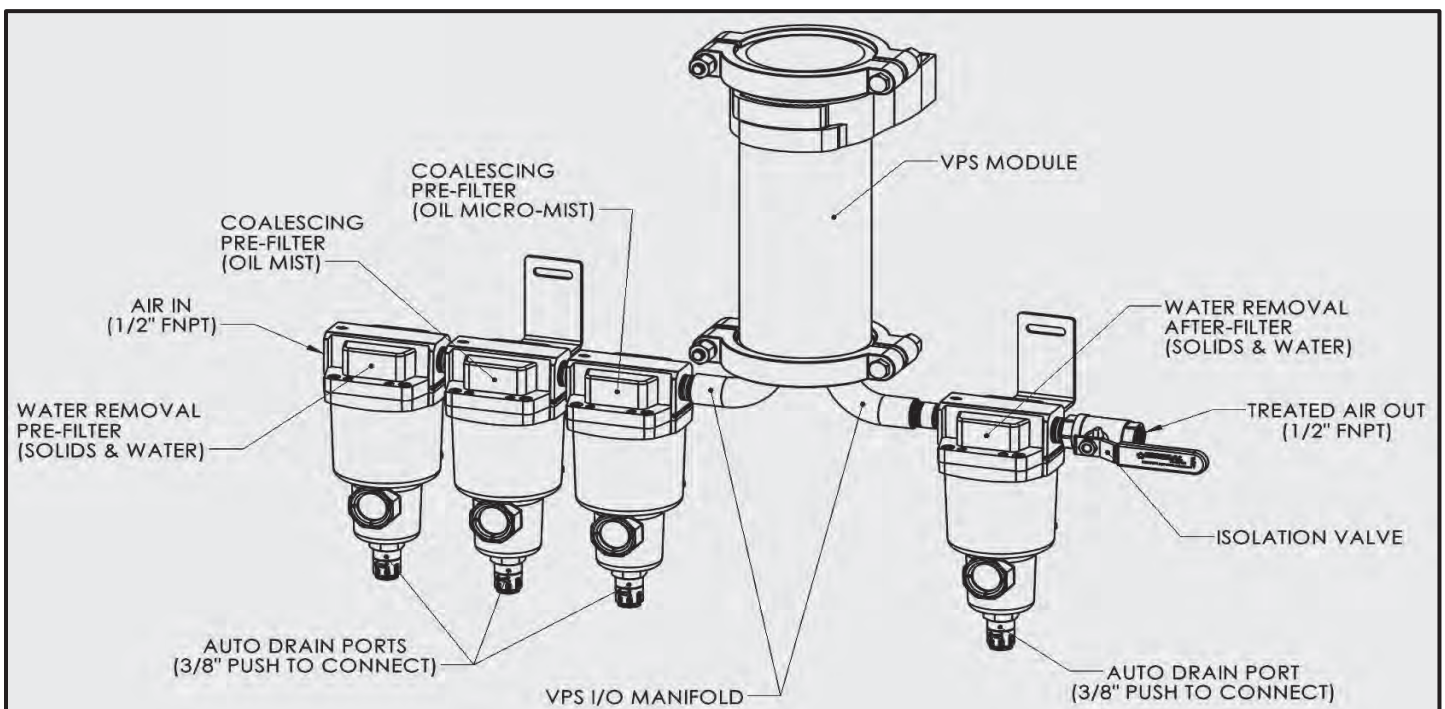
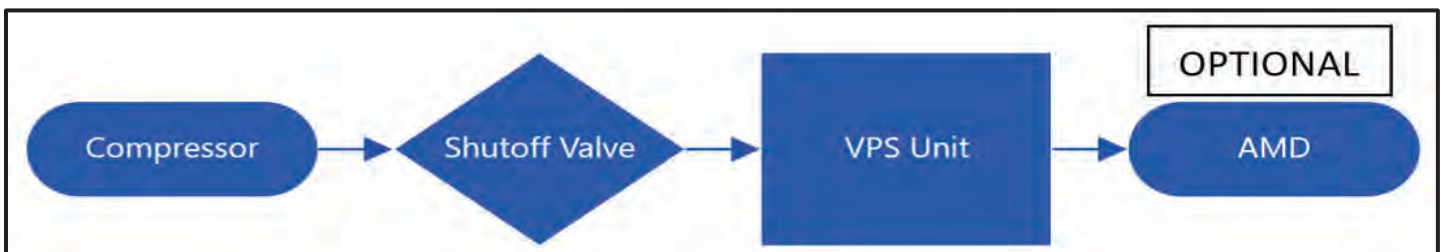

4 START-UP INSTRUCTIONS

With all the connections made as described in “**SECTION 3; INSTALLATION – (PG. 5)**”, the Vapor Pipe Shield (VPS) unit is ready to start. The following measures should be undertaken anytime a VPS unit is installed. Filters shown may appear differently than actual filters used. All filters should be maintained and operated according to the maintenance schedule and procedures within this manual.

- 1) **Depressurize the entire dry-pipe sprinkler system** to atmosphere (0 PSIG).
- 2) If an Air Storage Tank(s) is present before the VPS unit, the **Tank(s) should be completely drained of water** prior to start, and ensure all fittings are installed and tightened properly.



WARNING

Failure to check all pressurized fittings may result in a potentially hazardous situation which COULD result in death or serious injury. All components under pressure must be inspected before use.

- 3) With both the Shutoff Valves directly before and after the VPS unit closed, and any Air Maintenance Device (sold separately) closed, as shown in the diagram below; turn on the Air Source to pressurize the lines up to the first closed inlet Shutoff Valve (sold separately) to standard operating pressure for that equipment.



NOTICE

Although a Shutoff Valve on the inlet side of the VPS unit is recommended, it is NOT required. In such cases, specific instructions for operation of the inlet Shutoff Valve may be disregarded; however, continue to follow all other instructions as described.

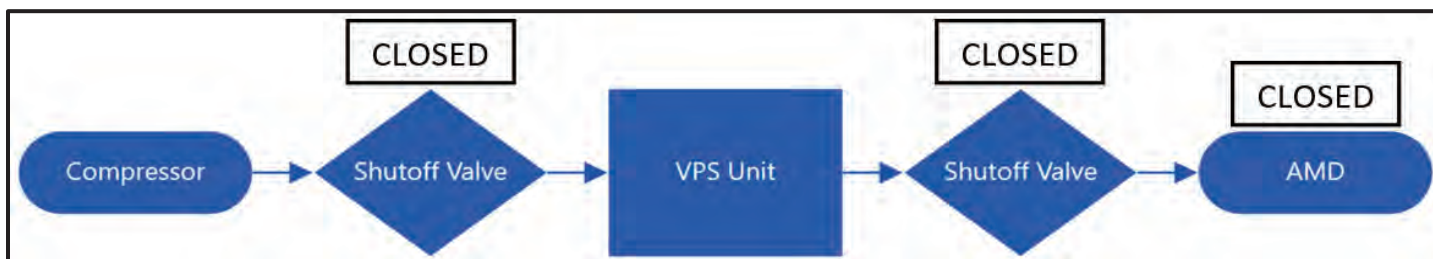

- 4) Check all parts and fittings on the VPS unit for tightness, and confirm that all Drain Ports on the VPS unit are set to the closed position by rotating the knob at the very bottom of each filter bowl (x4 total) **Counter-Clockwise** in the direction marked “**S**”, as shown in the adjacent figure.

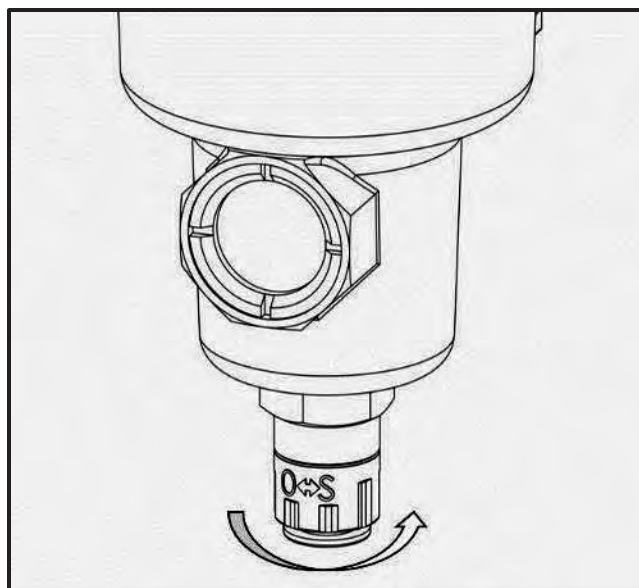

- 5) Slowly open the inlet Shutoff Valve directly before the VPS unit, if utilized, to pressurize the VPS unit as shown in the diagram below. Note that while the air source pressurizes the VPS unit, the filters may temporarily purge air until enough pressure is built up to seal their respective Drain Ports.



- 6) Once the pressurization of the VPS unit is complete, perform a leak test and take measures to fix any leaks found, then slowly open the VPS discharge Shutoff Valve, as shown in the diagram below.



WARNING

Failure to perform a leak test or check all parts & fittings for tightness may result in a potentially hazardous situation which COULD result in death or serious injury. All components under pressure must be inspected before use.



- 7) If utilized, set the Air Maintenance Device (sold separately) to the proper operating pressure for the dry-pipe sprinkler system and place it in Bypass Mode for the duration of the system fill, as shown in the diagram below.



- 8) After system fill, if utilized, return the Air Maintenance Device (sold separately) to Regulator Mode, as shown in the diagram below.



5 OPERATION

5.1 INITIAL FILTRATION (PRE-FILTERS)

Air is produced from an air source (for example from an air compressor) and is directed into the Pre-filters of the Vapor Pipe Shield (VPS) unit. The first pre-filter is a water removal filter, which removes large debris and bulk water from the airstream. Air then exits the first pre-filter and enters the second pre-filter. The second pre-filter acts as an initial-stage 0.1-micron coalescing filter, which removes particles, oil mist, and additional water condensate. Air then exits the second pre-filter and enters the third pre-filter. The third pre-filter acts as a secondary-stage 0.01-micron coalescing filter, which removes additional particles, oil mist, and additional water condensate. These three Pre-filters are all identically configured with built-in automatic drains, which in service will expel their accumulated contents from their Drain Ports. These drains can be manually emptied by turning the knob at the bottom of each Drain Port clockwise, and resealed by turning the knob counter-clockwise.



These filters are equipped with 3/8" push to connect tube fittings so that their discharged contents may be sent to a remote drain or collection bin.

5.2 PROPRIETARY AIR TREATMENT (MODULE(S) & CARTRIDGE(S))

Air from the third pre-filter is then directed into the VPS Module(s) where it undergoes proprietary treatment. This treatment infuses the air with protective vapors and characteristics that defend against corrosion.

5.3 POST FILTRATION (AFTER-FILTER)

Following the air treatment, VPS protection-infused air is then directed from the Module(s), into an After-filter. This After-filter is a final water removal filter, which removes additional water droplets from the airstream. Additionally, this After-filter is equipped with a built-in automatic drain, which will expel accumulated particles & moisture from the bottom of the filters. The drain can be manually emptied by turning the knob at the bottom of the Drain Port clockwise, and resealed by turning the knob counter-clockwise. The After-filter is then connected to a Shutoff Valve.

5.4 PROTECTION DISPERSAL THROUGH THE DRY-PIPE SPRINKLER SYSTEM

VPS Protection-infused air is then directed from the Shutoff Valve, through any Air Maintenance Device (sold separately), and from there into the dry-pipe sprinkler system to be protected. The initial fill of the piping system starts the protection process. **If a VPS Purge Valve is not utilized**, the typical time for inhibitor coverage is **21 days or less**. Nothing further is required to protect the piping system from corrosion for one (1) year. **If a VPS Purge Valve is utilized**, the expected time for inhibitor coverage is **10 days or less**; during which, air from the dry-pipe sprinkler system is bled from the VPS Purge Valve (sold separately), thereby causing the air source to run at an increased rate. The resulting increase in flow of compressed air through the VPS unit in-turn causes VPS protection-infused air to be dispersed throughout the system at an accelerated rate. This purging process continues for 10 days, thus charging the system with VPS protection-infused air over the duration of this time. At the conclusion of the 10-day system charge, the purge (if utilized) must be shut off at the VPS Purge Valve. While either process is underway, protective vapors will self-migrate into main & branch lines. The protective vapors in the air stream will pull their way through and bond to the inner walls of the dry-pipe sprinkler system, and form a microscopic protective layer on the molecular level, thus shielding the inner walls of the piping from corrosion. Protection-infused air will continue to self-migrate over time throughout the dry-pipe sprinkler system, receiving a boost every time the air source repressurizes the system, thereby adding to and maintaining system protection for 1 year. After 1 year, the VPS Cartridge(s) and filter elements **MUST** be replaced to ensure continued & optimal protection. See "**SECTION 6: MAINTENANCE SCHEDULE – (PG. 22)**".

6 MAINTENANCE SCHEDULE

The Vapor Pipe Shield (VPS) unit requires **Annual Maintenance**, ideally when the sprinkler system is inspected. Maintenance Kits are available with all necessary materials for each Annual Maintenance Period. The adjacent table shows the specific Maintenance Kit required for each VPS unit. Filters shown may appear differently than actual filters used. All filters should be maintained and operated according to the maintenance schedule and procedures within this manual.

Packages	Kit #	Description
VPS-500A Maintenance Kit	VPS-500-MKA	Includes Replacement Filter Element(s) & Cartridge(s)
VPS-1000A Maintenance Kit	VPS-1000-MKA	Includes Replacement Filter Element(s) & Cartridge(s)
VPS-1500A Maintenance Kit	VPS-1500-MKA	Includes Replacement Filter Element(s) & Cartridge(s)
VPS-2000A Maintenance Kit	VPS-2000-MKA	Includes Replacement Filter Element(s) & Cartridge(s)

Packages	Kit #	Description
VPS-500B Maintenance Kit	VPS-500-MKB	Includes Replacement Filter Element(s) & Cartridge(s)
VPS-1000B Maintenance Kit	VPS-1000-MKB	Includes Replacement Filter Element(s) & Cartridge(s)
VPS-1500B Maintenance Kit	VPS-1500-MKB	Includes Replacement Filter Element(s) & Cartridge(s)
VPS-2000B Maintenance Kit	VPS-2000-MKB	Includes Replacement Filter Element(s) & Cartridge(s)

If one or more VPS Expansion Kits were added to the system, contact your local supplier, or General Air Products Technical Assistance at (800) 345-8207 for the correct Maintenance Kit.

6.1 STANDARD MAINTENANCE PROCEDURE (ANNUAL)

- 1) Isolate the VPS unit by closing any Shutoff Valves directly before and after the VPS unit.

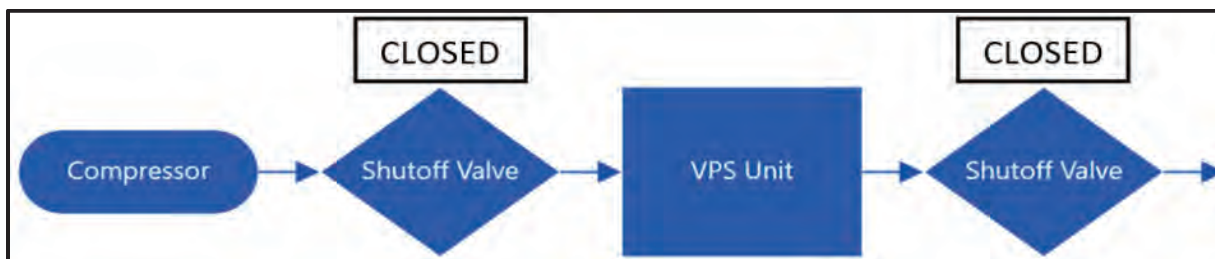

- 2) Depressurize the VPS unit to atmosphere (0 PSIG) by slowly opening the Drain Port on any filter. This can be accomplished by rotating the Knob at the very bottom of any filter **Clockwise** to the position marked "O". Do not disengage the bowl from any filter or attempt to loosen any other fittings to depressurize the VPS unit.

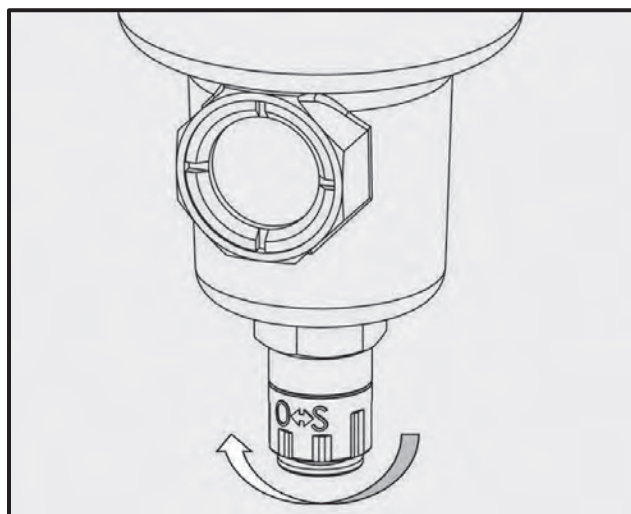

Failure to depressurize the VPS unit prior doing maintenance work on the VPS unit may result in a potentially hazardous situation which COULD result in death or serious injury. All components under pressure must be inspected before use.

- 3) After the VPS unit is depressurized to atmospheric pressure (0 PSIG), open the Upper Clamp (as described below), and remove & separate each Module from the assembly. A **5/8" wrench** can be used to remove all Bolted Clamps securing the Module(s), as shown in the adjacent figure.

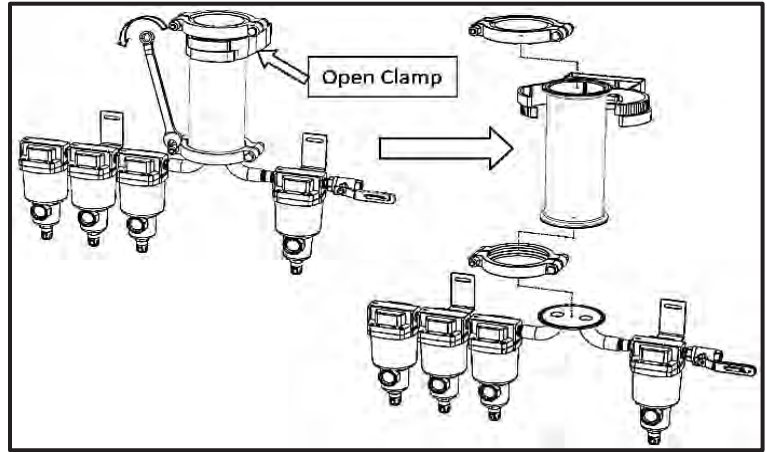

- 3a) Place fingers on the outside edges of the winged tabs, as depicted in the image below.



- 3b) Place thumbs towards the center, as depicted in the image below.



- 3c) Push with thumbs and pull with fingers to open the clamp, as depicted in the image below.



- 4) Remove the old Cartridge(s) & Spacer from the Module(s) by ***PUSHING*** a new Cartridge into each Module, and in the process ejecting each old Cartridge(s) & the Spacer. Then reinsert the Spacer in the 10" Module on the same side as the Cartridge's alignment pins. Note that ***only*** the 10" Module has a Spacer, the 8" Expansion Modules only have a Cartridge, see adjacent figure.

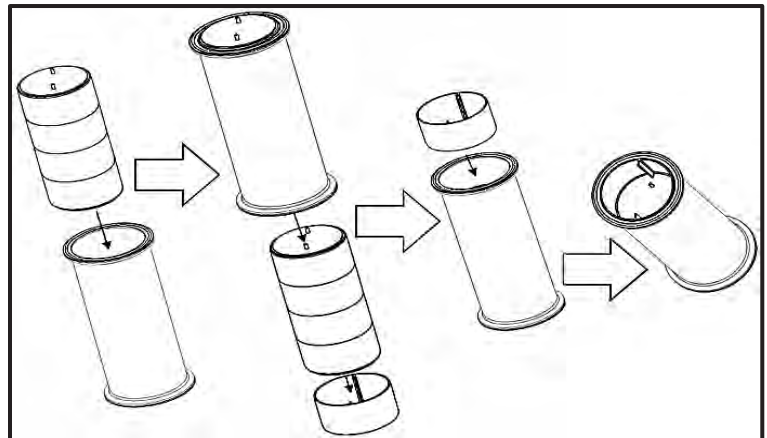

- 5) Dispose of the used Cartridge(s) & Gaskets by conventional means, in accordance with state and local guidelines if applicable. Save the Spacer, and store for later reuse, see adjacent figure.

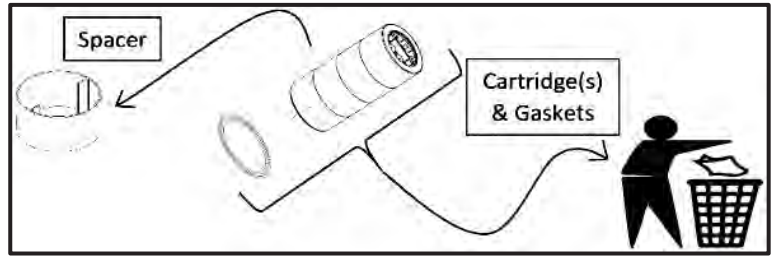

- 6) Reinstall the Cap and Bolted Clamp on the 10" Module (on the side with the Alignment Pins and the Spacer). A **5/8" Wrench** can be used on the two nuts to evenly secure the Bolted Clamp, see adjacent figure. **(Reference torque spec: 20 ft. lbs.)**

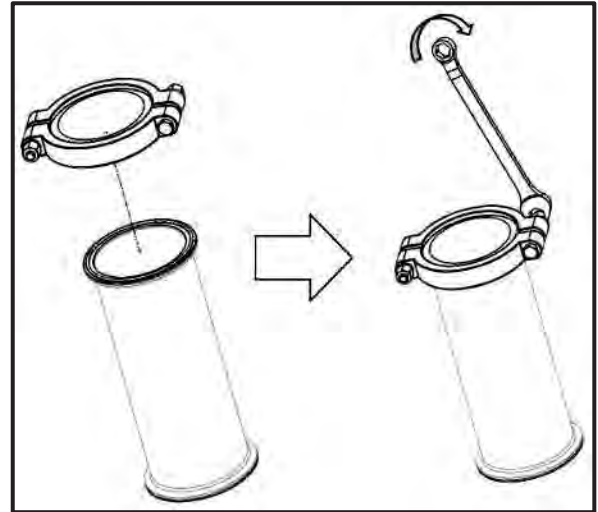

- 7) If a **Single Module** (VPS-500) is used, take the 10" Module with the Cap; and with the cap-side up, line up the I/O Manifold's inlet / outlet ports with the center of each of the Cartridge's chambers.

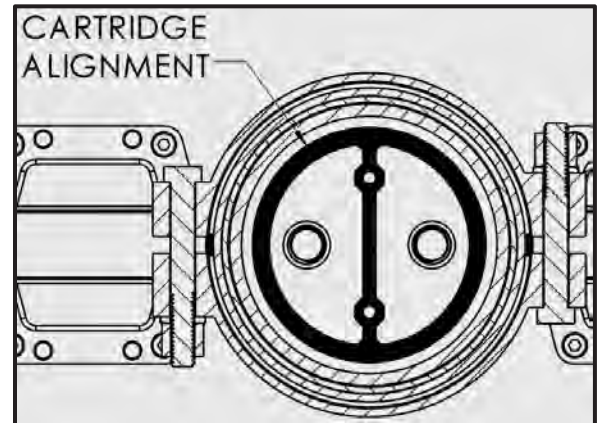

If **Multiple Modules** (VPS-1000 +) are used, stack the 8" Modules first, lining up the I/O Manifold's inlet / outlet ports with the center of each of the Cartridges' chambers. Then stack the remaining Modules on top of one-another, lining up the Cartridges' chambers & alignment pins with their mating Cartridge(s)'. The 10" Module with the Cap always goes on top.

A **5/8" wrench** can be used on the two nuts to evenly secure all Bolted Clamps. **(Reference torque spec: 20ft. lbs.)** See adjacent figures.

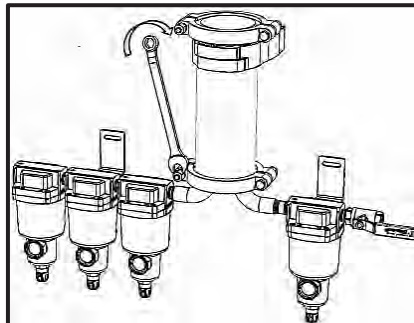
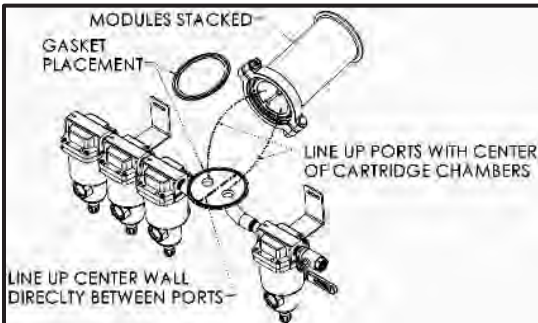
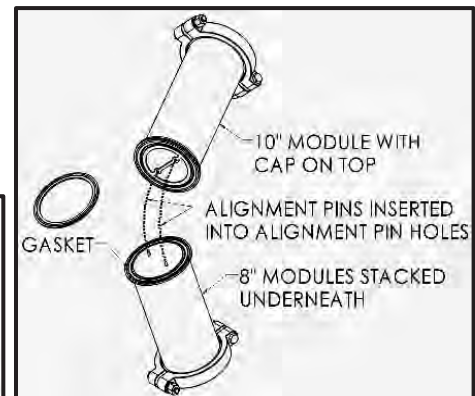

- 8) Remove the Filter Bowls by removing the screws (4 each) located on the top of each filter using a **4mm hex key**. Filter Elements 2 & 3 require replacement on an annual basis. Filter Elements 1 & 4 may be cleaned / replaced as needed. See adjacent figure.

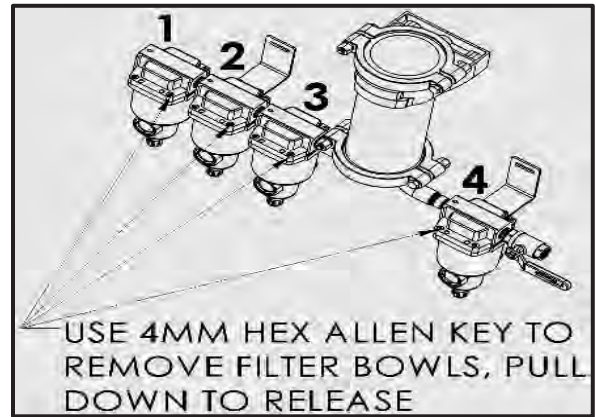

- 9) Dispose of the used Filter Elements located inside the Filter Bowls, and dispose of the O-Rings and Gaskets inside the Filter Heads, in accordance with state and local guidelines if applicable. Replace the Filter Elements inside the Filter Bowls with the hole-side of each facing up, and replace the O-Rings and the Gaskets inside the Filter Head. Then replace the filter bowls & screws on each filter using a **4mm hex key**. Ensure all O-rings / Gaskets are in place as shown prior to reassembling. See figures below.



- 10) If an Air Storage Tank(s) is present before the VPS unit, the Tank(s) should be completely drained of water prior to start, and ensure all fittings are installed and tightened properly.



WARNING

Failure to check all pressurized fittings may result in a potentially hazardous situation which COULD result in death or serious injury. All components under pressure must be inspected before use.

- 11) With both the Shutoff Valves directly before and after the VPS unit closed, and any Air Maintenance Device (sold separately) closed, as shown in the diagram below; turn on the Air Source to pressurize the lines up to the first closed inlet Shutoff Valve (sold separately) to standard operating pressure for that equipment.



NOTICE

Although a Shutoff Valve on the inlet side of the VPS unit is recommended, it is NOT required. In such cases, specific instructions for operation of the inlet Shutoff Valve may be disregarded; however, continue to follow all other instructions as described.

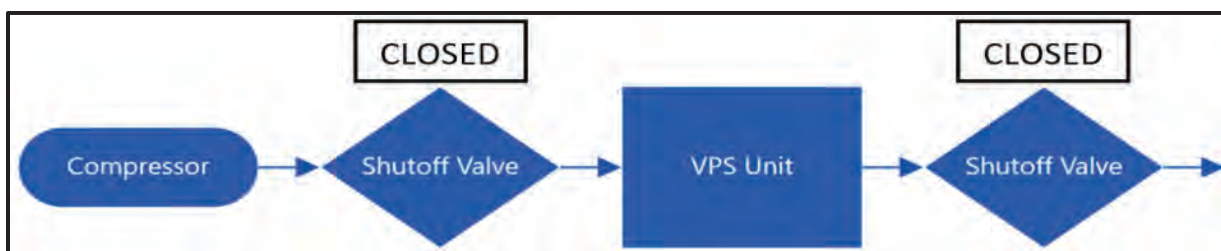

12) Check all parts and fittings on the VPS unit for tightness, and confirm that all Drain Ports on the VPS unit are set to the closed position by rotating the knob at the very bottom of each filter bowl (x4 total) **Counter-Clockwise** in the direction marked “S”, as shown in the adjacent figure.

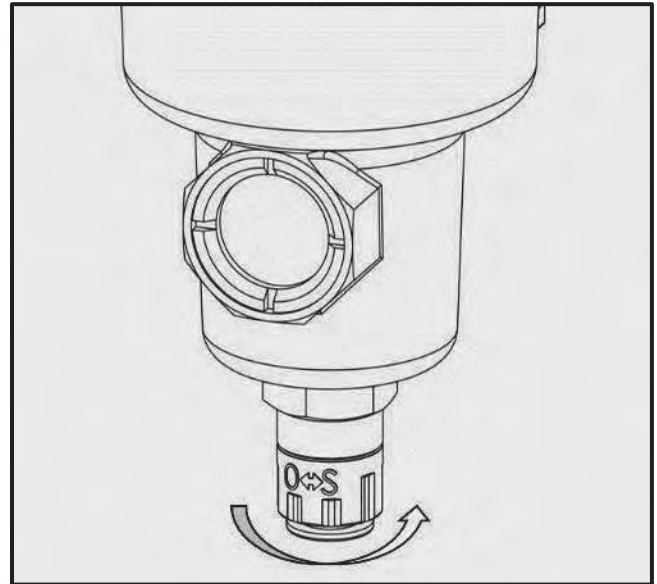

13) Slowly open the inlet Shutoff Valve directly before the VPS unit to pressurize the VPS unit as shown in the diagram below. Note that while the air source pressurizes the VPS unit, the filters may temporarily purge air until enough pressure is built up to seal their respective Drain Ports.

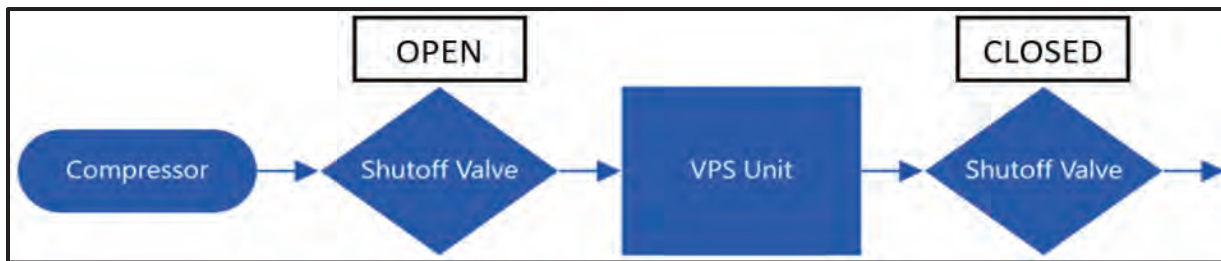

14) Once the pressurization of the VPS unit is complete, perform a leak test and fix any leaks found, then slowly open the VPS discharge Shutoff Valve, as shown in the diagram below.



WARNING

Failure to perform a leak test or check all parts & fittings for tightness may result in a potentially hazardous situation which COULD result in death or serious injury. All components under pressure must be inspected before use.

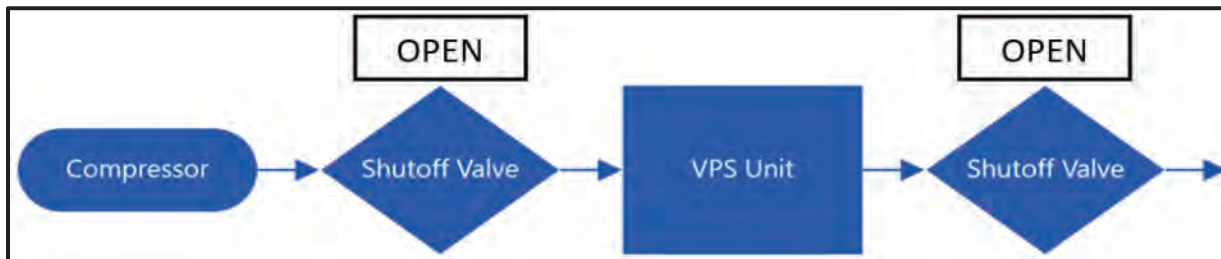

7 TROUBLESHOOTING

The following table describes several possible (but not all) troubleshooting scenarios with possible solutions that may be experienced over the life of Vapor Pipe Shield (VPS). Every system is unique with its own set of specific circumstances and unique characteristics. However, contaminants or other foreign materials within a sprinkler system may adversely impact the properties and performance of VPS, and may void manufacturer warranty.

Problem	Possible Causes	Solution
----------------	------------------------	-----------------

Excessive Pressure Drop	A valve is partially or fully shut	Ensure all valves are in correct position
	Clogged filters	Change filter elements
	Unit or filters flooded	Replace two filter elements and the VPS cartridge
	Cartridge breakdown	Change cartridge
	Filter elements installed upside-down	Flip the filter elements inside the filter bowls so that the hole-side of each filter element is facing up

Fails to Pressurize	A valve partially or fully open	Ensure all valves are in correct position
	Filters left open	Close filter ports
	Leak in VPS unit	Depressurize and repair leak/replace damaged parts
	Filter elements installed upside-down	Flip the filter elements inside the filter bowls so that the hole-side of each filter element is facing up
	Filter drain ports left open	Close filter drain ports

8 GENERAL ARRANGEMENTS

8.1 SAMPLE SYSTEM LAYOUT

(NOT TO SCALE)

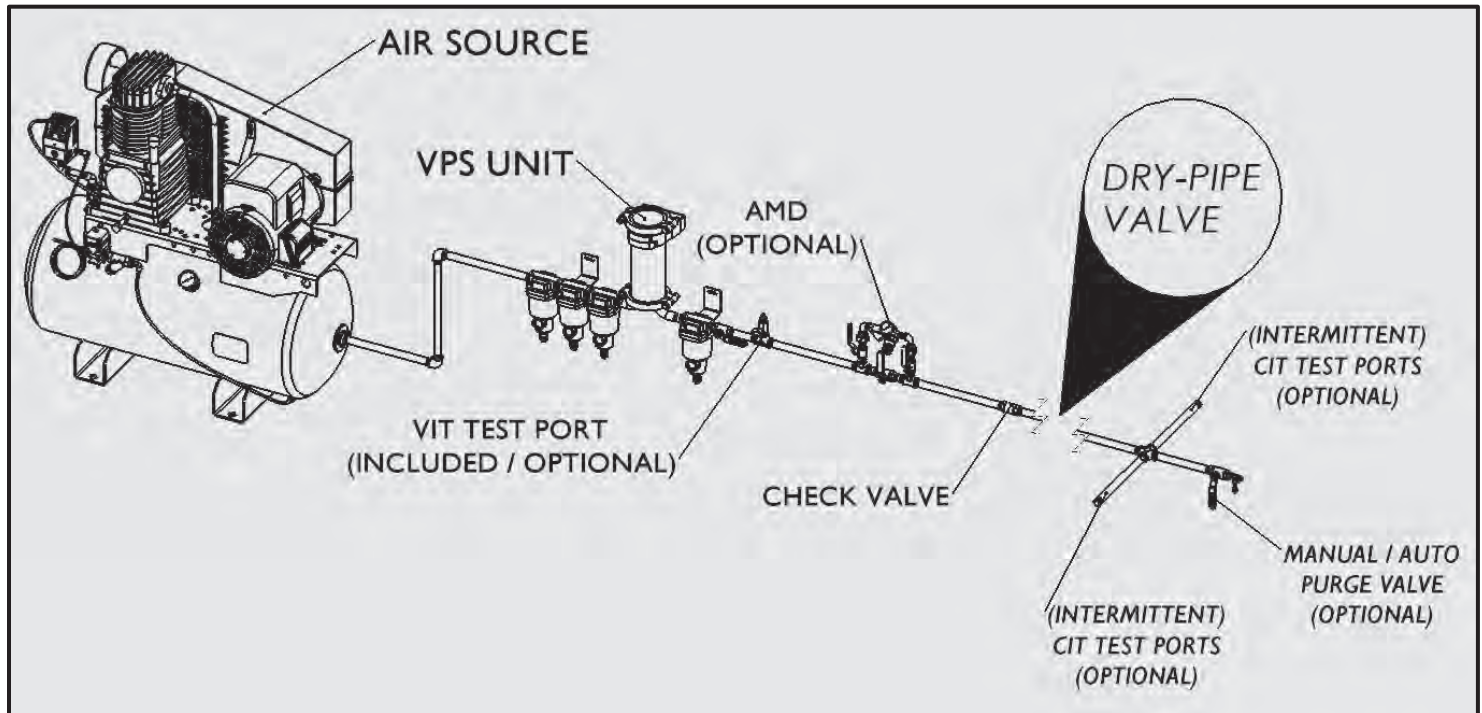

8.2 FEATURE LAYOUT

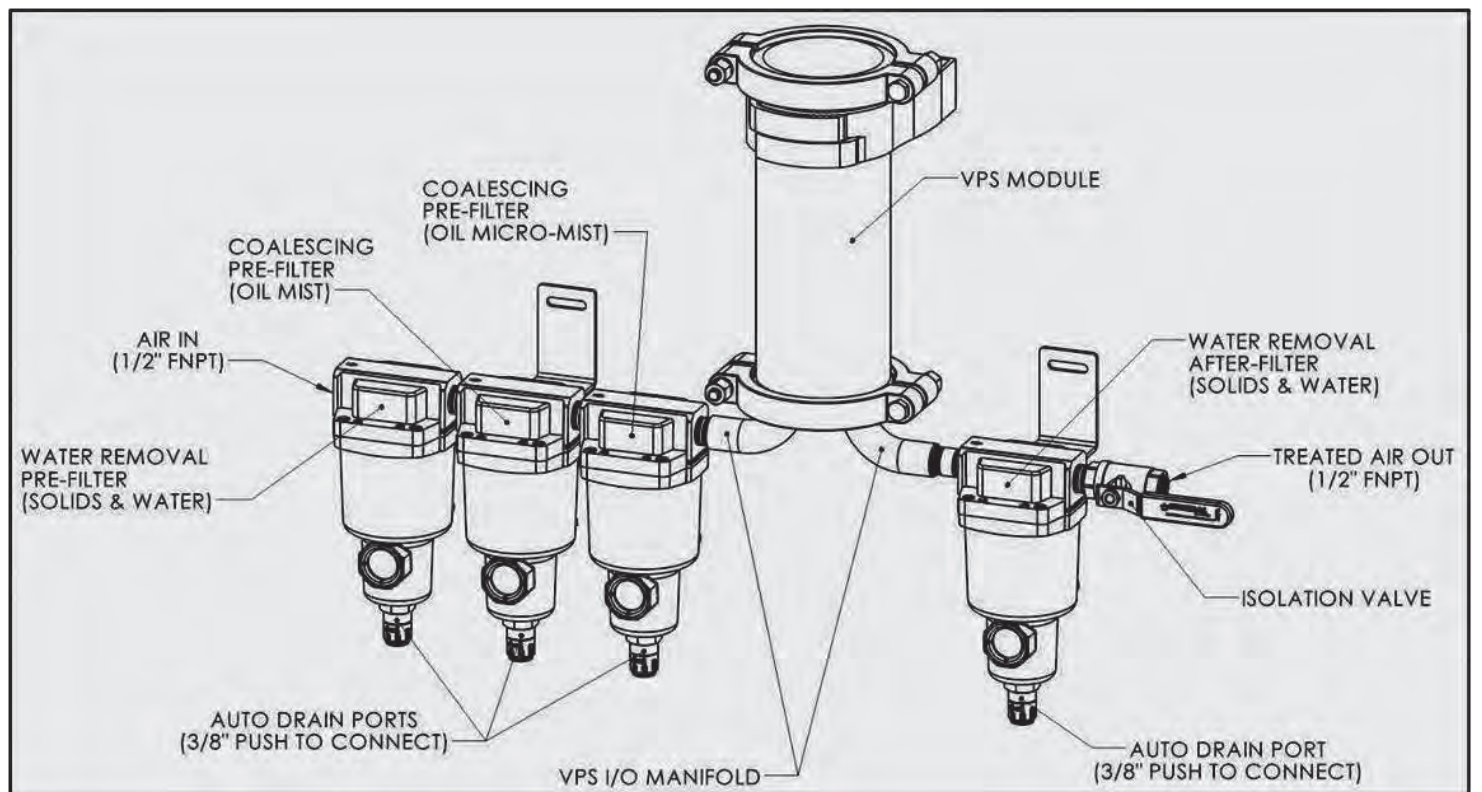

8.3 MAINTENANCE SCHEDULE CONNECTIONS

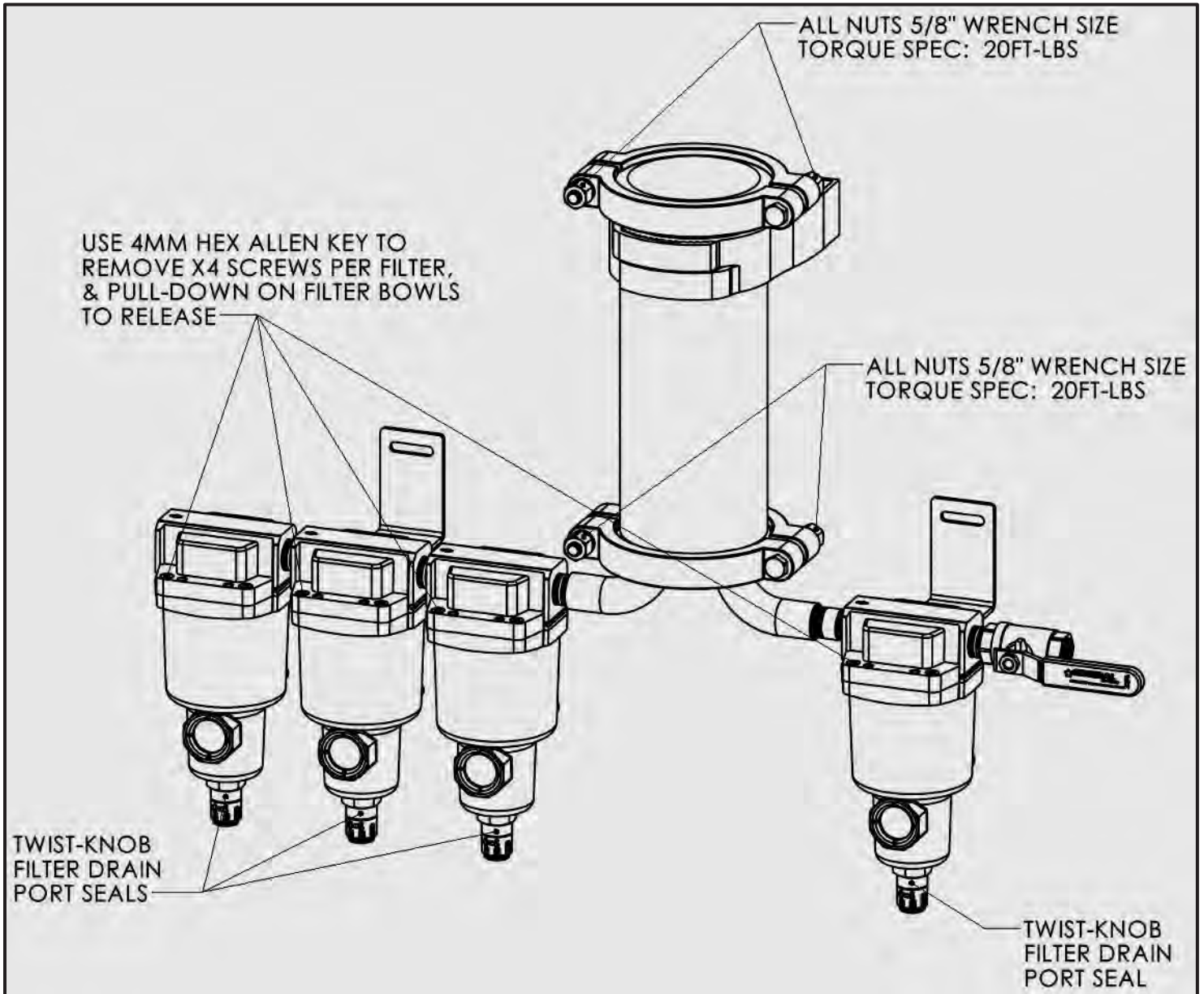

8.4 MODULE/ CARTRIDGE ARRANGEMENT

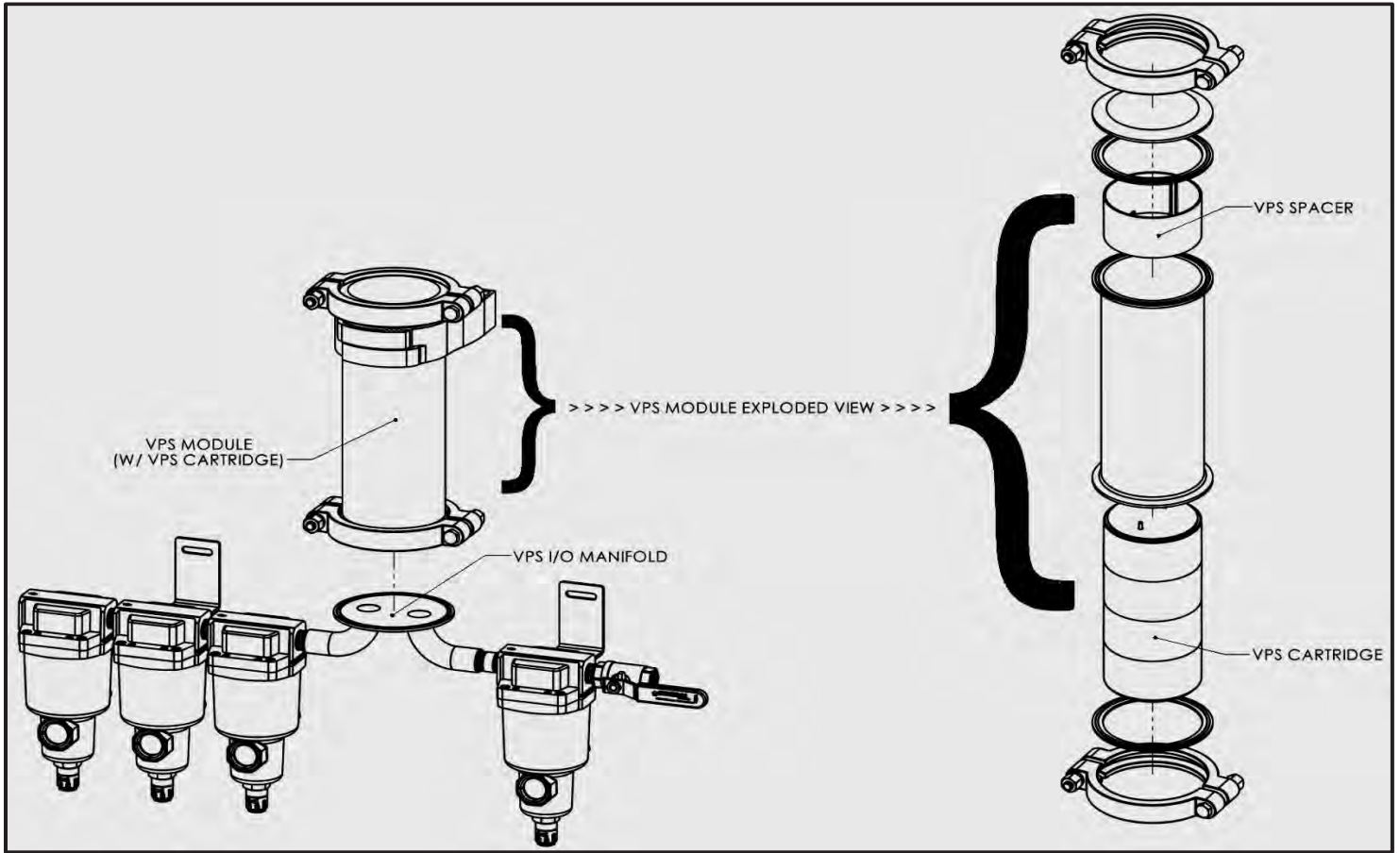

8.5 GENERAL ARRANGEMENT

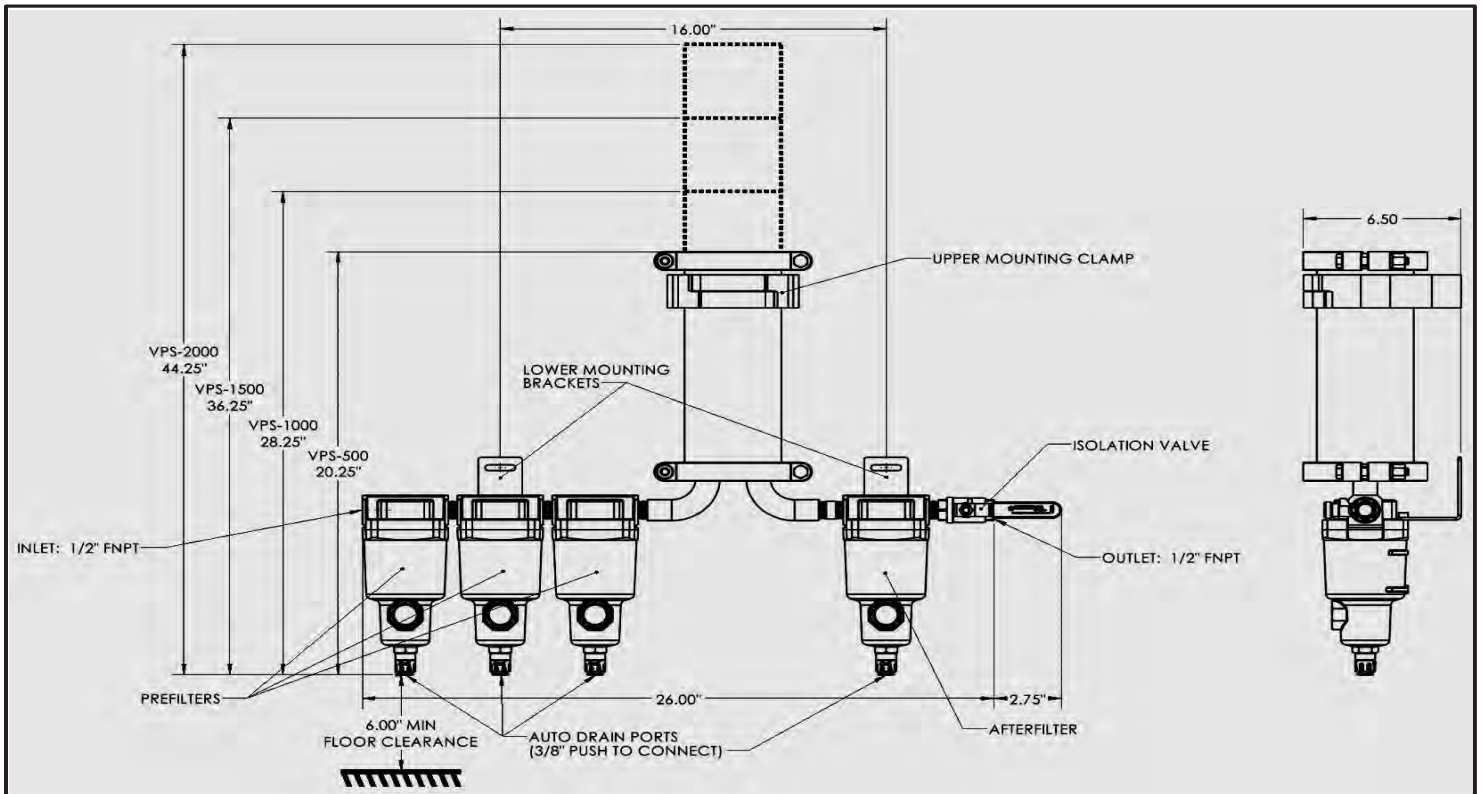

9 WARRANTY POLICY

GENERAL PROVISIONS & LIMITATIONS

General Air Products, Inc. (the "Company") warrants to each original purchaser ("Purchaser") of its new products from the Company or its Authorized Distributor that such products are, at the time of delivery to the Purchaser, made with good materials and workman- ship. No warranty is made with respect to:

1. Any product, which has been repaired or altered in such a way, in the Companies judgment, as to affect the product adversely.
2. Any product, which has, in the Companies judgment been subjected to negligence, accident, improper storage, improper installation or application.
3. Any product, which has not been operated or maintained in accordance with the recommendations of the Company.
4. Components or accessories manufactured, warranted and serviced by others.
5. Any reconditioned or prior owned product.

Claims for items described in 4. above should be submitted directly to the manufacturer.

WARRANTY PERIOD

The Company's obligation under this Warranty is limited to repair or, at its option, replacing during normal business hours at the designated facility of the Company, any part that in its judgment proved not to be as warranted within the applicable Warranty Period as follows.

COMPONENTS

All non-consumable components are warranted for 12 months from the date of purchase. Consumables are not covered under warranty. The unit must have been installed by either a factory authorized distributor or agent in accordance with the factory recommendations taking into account all other local site conditions not originally noted to the factory. The unit must be operated and maintained in accordance with the Factory recommendations and original design conditions. Failure to provide such proof of the above may void warranty.

LABOR TRANSPORTATION & INSPECTION

The Company will repair or replace any product or part thereof which in the Companies judgment is proved to be not as warrant- ed. Labor costs are not covered under warranty.

All costs of transportation of product, labor or parts claimed not to be as warranted and, of repaired or replaced parts to or from factory shall be borne by purchaser. The Company may require the return of any part claimed not to be as warranted to one of its facilities as designated by the Company, transportation prepaid by Purchaser, to establish a claim under this warranty.

Replacement parts provided under the terms of the warranty are warranted for the remainder of the Warranty Period of the product upon which installed to the same extent as if such parts were original components.

DISCLAIMER

THE FOREGOING WARRANTY IS EXCLUSIVE AND IT IS EXPRESSLY AGREED THAT, EXCEPT AS TO TITLE, THE COMPANY MAKES NO OTHER WARRANTIES, EXPRESSED OR IMPLIED OR STATUTORY, INCLUDING ANY IMPLIED WARRANTY OR MERCHANTABILITY.

THE REMEDY PROVIDED UNDER THIS WARRANTY SHALL BE THE SOLE, EXCLUSIVE AND ONLY REMEDY AVAILABLE TO THE PURCHASER AND IN NO CASE SHALL THE COMPANY BE SUBJECT TO ANY OTHER OBLIGATIONS OR LIABILITIES. UNDER NO CIRCUMSTANCES SHALL THE COMPANY BE LIABLE FOR SPECIAL, INDIRECT, INCIDENTAL OR CONSEQUENTIAL DAMAGES, EXPENSES, LOSSES OR DELAYS HOWSOEVER CAUSED.

No statement, representation, agreement, or understanding, oral or written, made by any agent, distributor, representative or employee of the Company which is not contained in this Warranty will be binding upon the company unless made in writing and executed by an officer of the Company.

This warranty shall not be effective as to any claim which is not presented within 30 days after the date upon which the product is claimed not to have been as warranted. Any action for breach of this warranty must be commenced within one year after the date upon which the cause of action occurred.

Any adjustment made pursuant to this warranty shall not be construed as an admission by the Company that any product was not as warranted.

PROMPT DISPOSITION & RETURNS POLICY

The Company will make a good faith effort for prompt correction or other adjustment with respect to any product, which proves to be defective within the warranty period. Before returning any product, write or call the distributor, agent or authorized company from which the product was purchased, describing defect and giving date and number of original invoice(s), as well as proof of Factory supplied consumables and proof of scheduled maintenance. No products will be accepted for return without the Company issuing a "Returned Goods Authorization" (RGA) to the Purchaser and unless accompanied by a properly authorized RGA request form initiated by the Purchaser. Return freight must be prepaid and each returned product must have the RGA number clearly marked on the product. Title and risk of loss pass to buyer upon delivery to the common carrier.

PRODUCT SUITABILITY

Many States, Localities and Countries have codes and regulations governing sales, construction, installation, and/or use of products for certain purposes, which may vary from those in neighboring areas. While General Air Products, Inc. attempts to assure that its products comply with such codes, it cannot guarantee compliance, and cannot be responsible for how the product is installed or used. Before purchase and use of a product, please review the product application, and national and local codes and regulations, and be sure that the product, installation, and use will comply with them.

General Air Products, Inc.

118 Summit Drive

Exton, PA 19341

P: 610-524-8950

REV:4/22/11

