

Oil-Less Tank Mount Fire Protection Air Compressors
for Dry Pipe & Pre-Action Sprinkler Systems.

OL Plus Series

General Air Products newly improved OLT Plus Series Oil Less Tank Mounted Fire Protection Air Compressors are specifically designed to fill dry pipe and pre-action fire sprinkler systems to 2.7 BAR within 30 minutes per NFPA 13



Includes 762mm Stainless Steel Flex Hose & Union and Vibration Pads.



System Capacity (L)* @2.7 BAR	Model Number	Average LPM**	Motor kW	Voltage (volts)	Amperage (amps)		Recommended Wire Size (mm ²)			Tank Size (L)	Unit Weight (kg)
					FLA	Start Up	8m Run	15m Run	30m Run		
362	OLT12016AC-50	33	.12	220-240	2.0	14	3	3	3	38	38
785	OLT25033AC-50	71	.25	220-240	4.3	30	3	3	3	38	40
1257	OLT40050AC-50	114	.56	220-240	7.5	53	3	3	6	38	45
1571	OLT50075AC-50	142	.75	220-240	7.5	53	3	3	6	38	45
1885	OLT600100AC-50	171	1.2	220-240	7.5	53	3	3	6	38	45
2870	OLT915150AC-50	260	1.5	220-240	6.3	44	3	3	6	76	61
3840	OLT1225200AC-50	348	2	220-240	8.8	62	3	3	6	76	66

Features and Benefits

- 50Hz Oil-Less Piston Compressor
- UL Listed, Pre-Set Pressure Switch
- Permanently lubricated bearings
- Fully Automatic, Direct Drive
- ASME Pressure Safety Valve
- Bubble Tight Air Check Valve
- Pre-Wired & Pre-Tested
- Lifetime Technical Support
- Includes Vibration Pads, 762mm Stainless Steel Flex Hose & Union

* System Capacity based on 30min fill at 2.7 BARG and 21°C system temperature.

** LPM is based on the average free air delivery as the system fills from 0 to 2.7 BARG.

Note: A listed Air Maintenance Device must be installed in conjunction with all Tank Mounted air compressors.

Note: All information is subject to change without notice. Consult factory for most up-to-date product details.

OL Plus Series Tank Mounted Fire Protection Air Compressors Accessories

VAPOR PIPE SHIELD



Vapor Pipe Shield is a Patented and UL Listed innovative solution for the prevention of corrosion in Dry-Pipe & Pre-Action Fire Sprinkler Systems.

AIR MAINTENANCE DEVICE



Part # AMD-1

The AMD-1 regulates the volume of air being delivered to the sprinkler system by the air compressor.

An Air Maintenance Device is required on all dry pipe systems when using a tank mounted air compressor.

MOTOR LINE STARTER



Thermal Overload Protection

SINGLE PHASE MOTOR LINE STARTERS				
	110V	220-240V	Size	Model
MAX kW	.25 kW	.75 kW	00	MG00A
	.75 kW	1.5 kW	0	MG00A
	1.5 kW	2.2 kW	1	MG01A
	2.2 kW	3.7 kW	1P	MG15A

When Ordering a Motor Starter you must specify kW, Voltage & Phase.

OL Plus Series Tank Mounted Fire Protection Air Compressors

MODEL: OLT12016AC-50

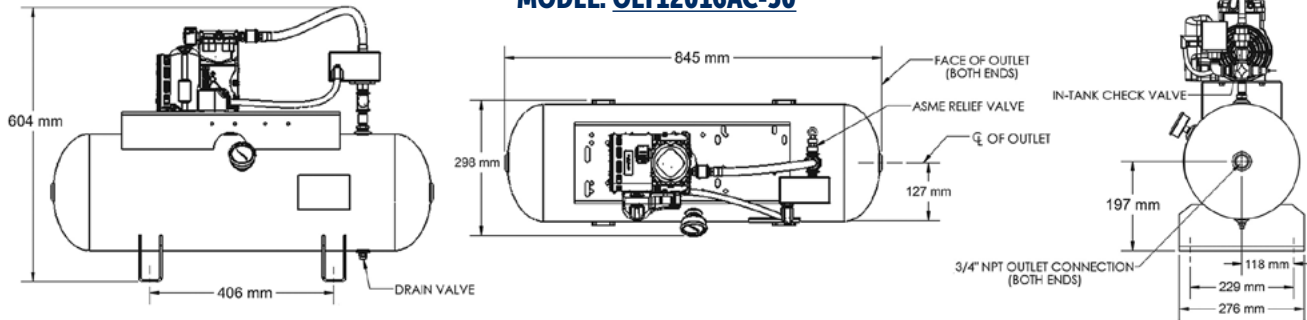

MODEL: OLT25033AC-50

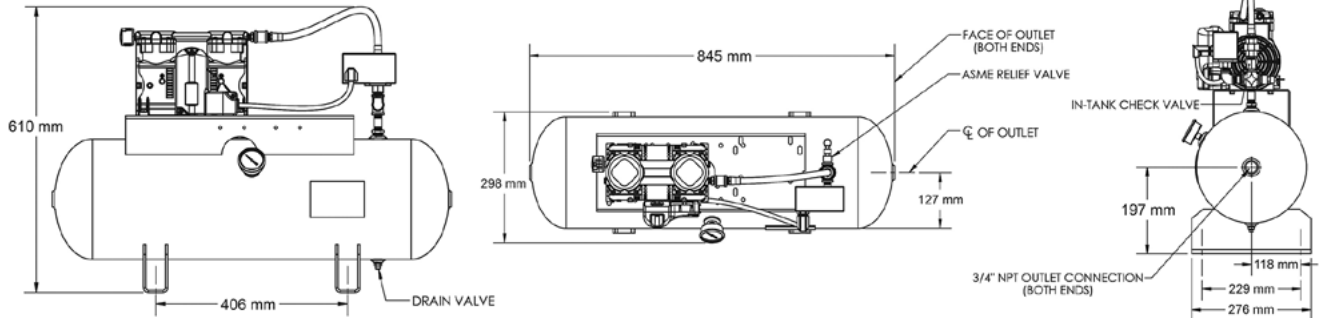

MODEL: OLT40050AC-50 | OLT50075AC-50 | OLT600100AC-50

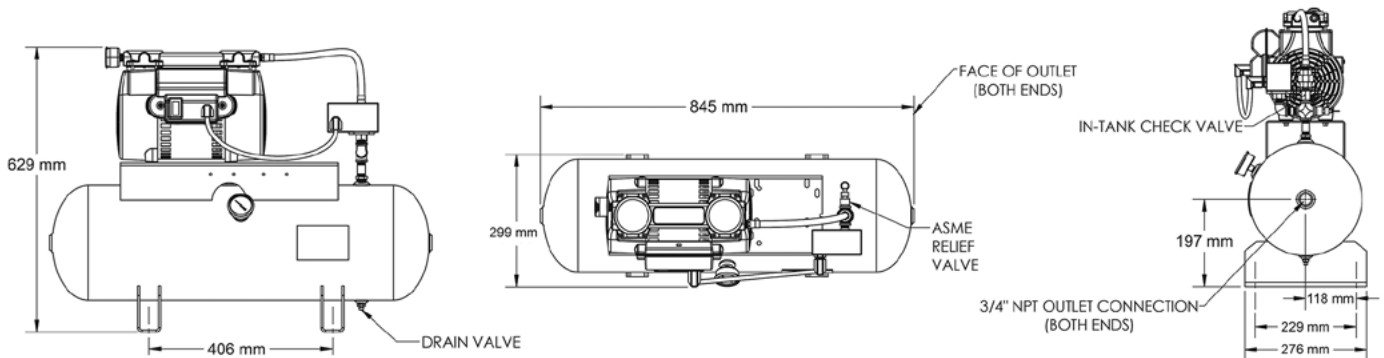

MODELS: OLT915150AC-50 | OLT12252005AC-50

