



## Quiet, Tank Mounted Air Compressors for Dry Pipe & Pre-Action Sprinkler Systems

QLTV250

### Introducing the most advanced Fire Protection Air Compressors ever built!

The Q Advance Series Tank Mounted Air Compressors Feature an all-new, UL 508 Listed, General Air Products Digital Pressure Switch. Designed to run at an average of 58 dBA, this is a 20 dBA drop from our standard OL Series. The Q Advance Series Air Compressors are specifically designed to fill dry pipe and pre-action fire sprinkler systems to supervisory pressure within 30 minutes per NFPA 13.



#### New Digital Pressure Switch:

The ONLY UL Listed Digital Pressure Switch in the Fire Protection industry designed and built by the compressor manufacturer themselves.

Displays Pressure Readings, Run Hours, Amps, Cycles, and is extremely easy to adjust pressure settings in the field. The Digital Pressure Switch also actuates an Automatic Drain Valve. (Tank mounted units only)

#### The Q Advance Series With A Digital Pressure Switch

- Whisper Quiet Motor
- Oil-Less Piston Compressor
- UL Listed, Digital Pressure Switch
- Fully Automatic Tank Drain Valve
- Includes Vibration Pads, 30" Stainless Steel Flex Hose & Union
- ASME Pressure Safety Valve
- Bubble Tight Air Check Valve
- Pre-Wired & Pre-Tested
- Lifetime Technical Support

System Capacity (gal)* @ 40 PSI	Model Number	Decibel Rating (dBA)	Average CFM**	Motor HP	Voltage (volts)	Amperage (amps)		Recommended Wire Size (gage)			Unit Weight (lbs)
						FLA	Start Up	25' Run	50' Run	100' Run	
135	QLTV13525AC	55	1.66	1/4	115	3.9	23.4	12	12	12	93
250	QLTV25050AC	58	2.72	1/2	115	7.7	46.2	12	12	10	100
500	QLTV500100AC	61	5.4	1	115	12.2	73.2	12	10	8	115

\* System Capacity based on 30 min fill at 70°F system temperature.

\*\* CFM is based on the average free air delivery as the system fills from 0 to 40 PSIG.

Note: All information is subject to change without notice. Consult factory for most up-to-date product details.

 WARNING: Cancer and Reproductive Harm - [www.p65warnings.ca.gov](http://www.p65warnings.ca.gov)



Note: All General Air Products compressors are OSHA compliant and und 85 dBA.

**MODEL:**  
**QLTV13525AC – 115V/1Ph/60Hz**

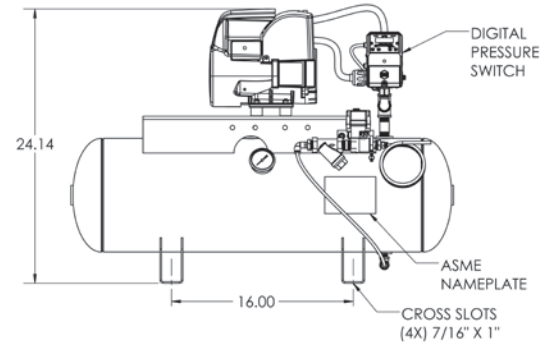
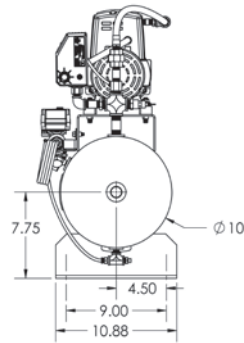
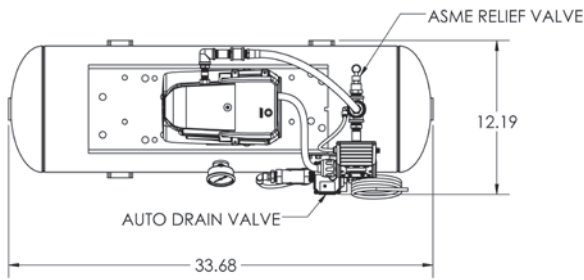

**MODEL:**  
**QLTV25050AC – 115V/1Ph/60Hz**

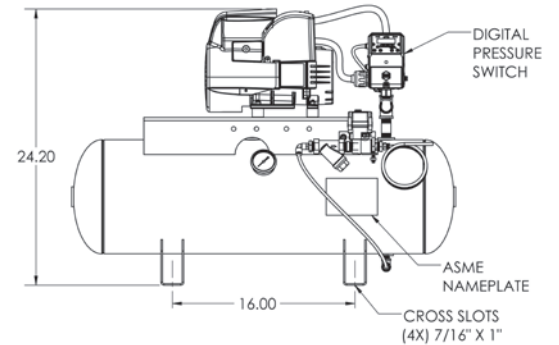
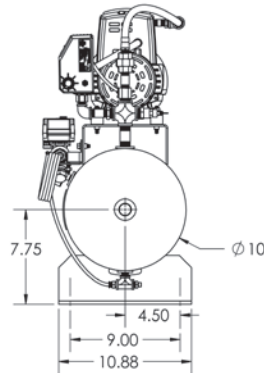
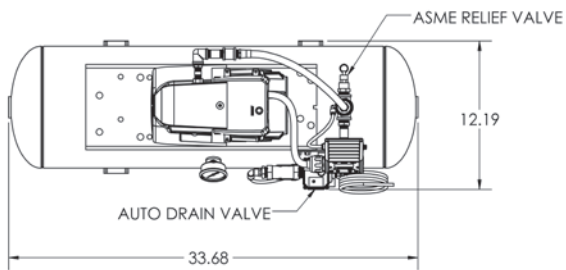

**MODEL:**  
**QLTV500100AC – 115V/1Ph/60Hz**

