

VAPOR-PHASE CORROSION INHIBITOR (VPCI®) SYSTEM

for Dry Pipe & Pre-Action Fire Sprinkler Systems

Vapor Pipe Shield is a delivery system for Vapor phase Corrosion Inhibitor (VpCI®) that is fully mechanical and piped directly in-line between the air compressor and the sprinkler valve. Air flow provided by the air compressor runs through the Vapor Pipe Shield unit and picks up VpCI® molecules that are carried into the sprinkler system and attracted to all metal surfaces. These molecules attach to the metal pipe forming a ONE MOLECULE LAYER or shield that acts as a barrier between the metal surface and the corrosive environment inside the pipe. The vapor moves quickly & efficiently throughout the entire system and even penetrates standing water, completely protecting all metal surfaces. Vapor phase Corrosion Inhibitors have been used and proven for decades as the most effective means of corrosion mitigation for a wide variety of industries. General Air Products is excited to introduce this technology to the Fire Protection Industry - making corrosion mitigation in any dry or pre-action fire sprinkler system simple, efficient, and highly cost-effective.

VAPOR
Pipe Shield

**Simplifying corrosion prevention in dry
& pre-action fire sprinkler systems.**

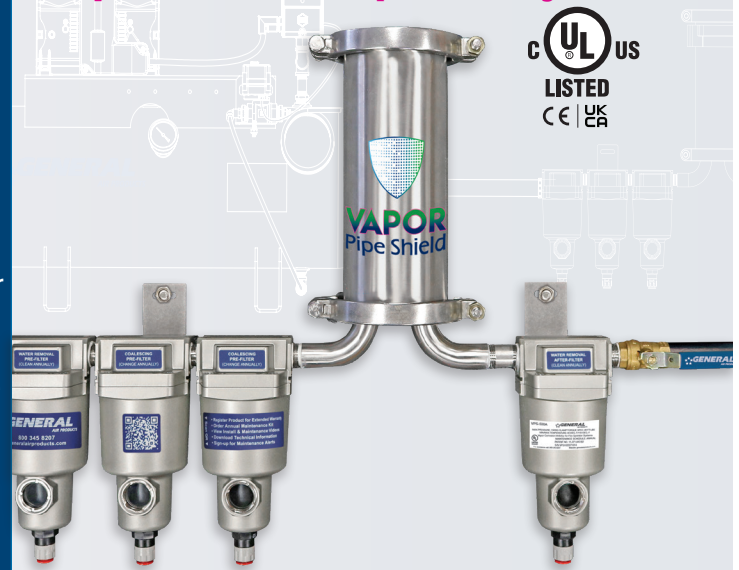

For use under Patent No. US 11,371,643 B2

Model Number	30 Min. Fill Capacity (Single System or Largest Riser)	Total System Capacity (Up to 4 Risers)	Inlet / Outlet Connections	Max Pressure	Dimensions (in)			Unit Weight (lbs)
					L	W	H	
VPS-500A	500 gal.	2000 gal.	1/2" FNPT	150 PSI	26	6.5	20.25	20
VPS-1000A	1000 gal.	4000 gal.	1/2" FNPT	150 PSI	26	6.5	28.25	26
VPS-1500A	1500 gal.	6000 gal.	1/2" FNPT	150 PSI	26	6.5	36.25	32
VPS-2000A	2000 gal.	8000 gal.	1/2" FNPT	150 PSI	26	6.5	44.25	38

Minimum Temperature: 40°F. / Maximum Temperature: 150°F.

⚠ WARNING: Cancer and Reproductive Harm - www.p65warnings.ca.gov

Note: All information is subject to change without notice. Consult factory for most up-to-date product details.

Features and Benefits

- UL Listed for Fire Protection
- Fully Pneumatic & Mechanical
- No Electrical Connections
- Easy To Install & Maintain
- Minimal Air Flow Loss
- Efficient & Effective
- Environmentally Safe
- No Purple Required

Included with Every Vapor Pipe Shield Unit

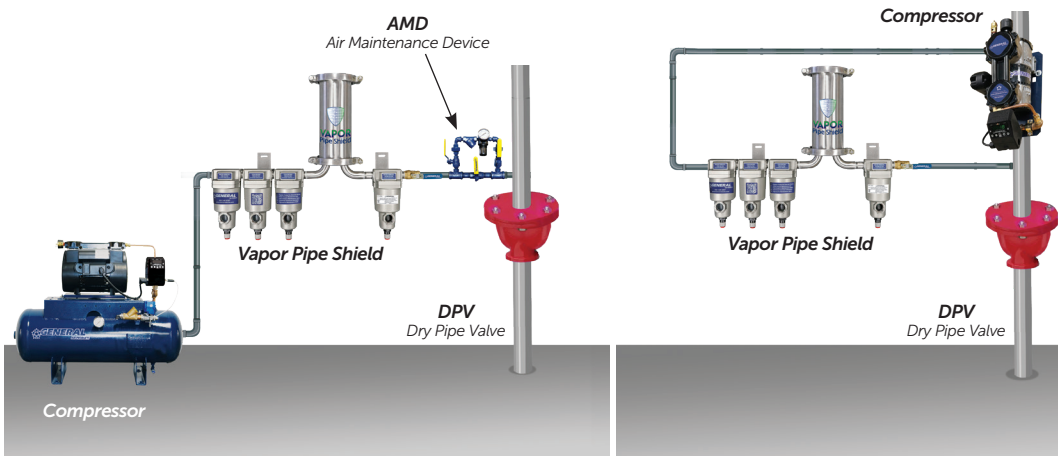
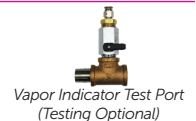
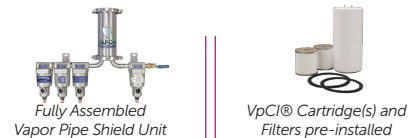

Vapor Pipe Shield

MODELS: VPS-500A

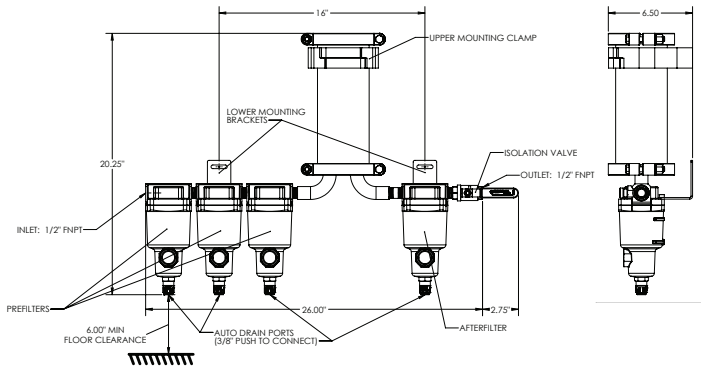

MODELS: VPS-1000A

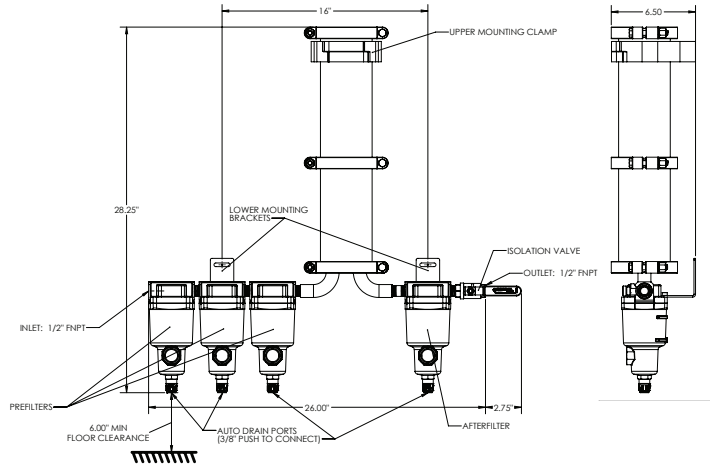

MODELS: VPS-1500A

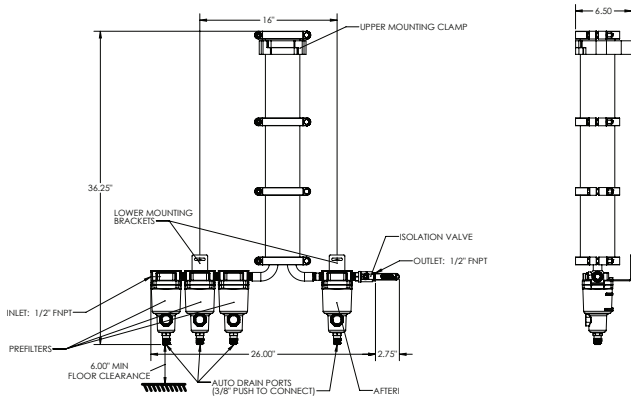

MODELS: VPS-2000A

