

SINGLE PHASE – 80/100 PSI

Oil-Less Riser Mount Fire Protection Air Compressors

for **High Pressure** Dry Pipe & Pre-Action Sprinkler Systems.

OL Plus Series

General Air Products newly improved OL Plus Series Oil Less Riser Mount Fire Protection Air Compressors are UL 1450-VDUR Listed and specifically designed to fill dry pipe and pre-action fire sprinkler systems to Supervisory Pressure within 30 minutes per NFPA 13.



Includes Riser Mounting Bracket, 30" Stainless Steel Flex Hose & Union.



System Capacity (gal)* @40 PSI	Model Number	CFM @10 PSIG	Motor HP	Voltage (volts)	Amperage (amps)		Recommended Wire Size (gauge)			Unit Weight (lbs)
					FLA	Start Up	25' Run	50' Run	100' Run	
250	OLR250-A-HP	3.03	1/3	115	4.3	30	12	12	10	33
				208-230	2.3	16	12	12	12	
400	OLR400-A-HP	4.85	1/2	115	9.4	66	12	10	6	45
				208-230	4.9	34	12	12	12	
500	OLR500-A-HP⁺	6.06 ⁺	3/4	115	9.9	69	12	10	6	45
				208-230	5.1	36	12	12	12	
600	OLR600-A-HP⁺	7.28 ⁺	1	115	11.3	79	12	10	6	45
				208-230	5.7	40	12	12	12	
915	OLR915-A-HP⁺	11.10 ⁺	1 1/2	115	16.6	116	12	8	8	60
				208-230	8.3	58	10	8	6	
1100	OLR1095-A-HP⁺	13.34 ⁺	2	208	11.3	79	10	8	6	70
				230	9.6	79	12	12	10	

Features and Benefits

- UL 1450-VDUR Listed
- CSA C22.2 No.68-Canada
- 100 PSI Max Pressure
- Oil-Less Piston Compressor
- UL Listed, Pre-Set Pressure Switch
- Fully Automatic, Direct Drive
- ASME Pressure Safety Valve
- Bubble Tight Air Check Valve
- Pre-Wired & Pre-Tested
- Includes Riser Mounting Bracket, 30" Stainless Steel Flex Hose & Union
- Lifetime Technical Support
- Annual Automated Maintenance Reminders

* System Capacity based on 30min fill-time at 70° F system temperature.

⁺ Compressor has a capacity above 5.5 CFM @ 10 PSIG. A listed Air Maintenance Device is required on systems supervised by this compressor per NFPA 13.

Note: All information is subject to change without notice. Consult factory for most up-to-date product details.



System Capacity (gal) by System Pressure

Model Number	@40 PSI	@50 PSI	@60 PSI	@70 PSI	@80 PSI	@90 PSI	@100 PSI
OLR250-A	250	190	155	125	105	90	75
OLR400-A	400	325	255	215	180	155	135
OLR500-A	500	360	290	240	200	170	145
OLR600-A	600	435	350	285	240	210	180
OLR915-A	910	680	525	420	340	280	240
OLR1095-A	1140	860	690	555	465	390	340

OL Plus Series High Pressure Riser Mount Fire Protection Air Compressors

MODEL: OLR250-A-HP

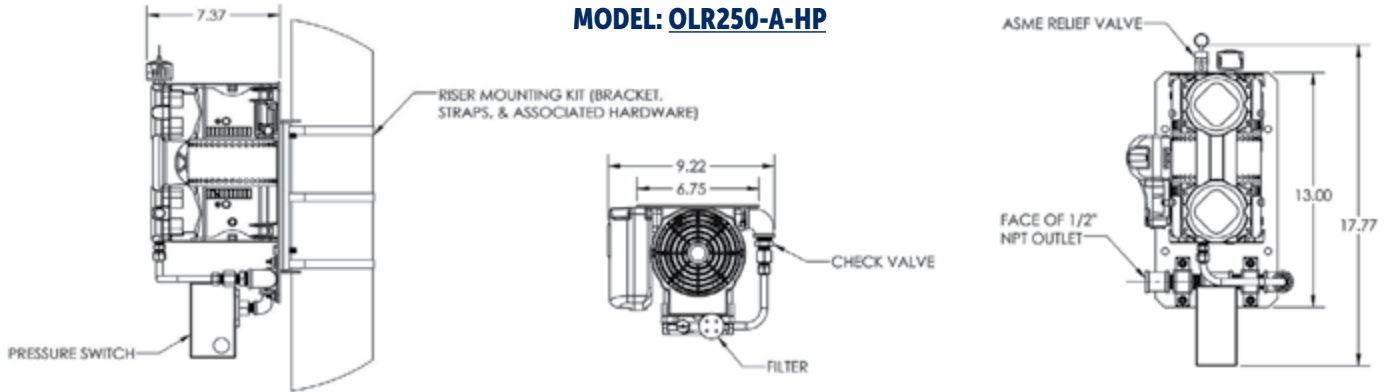

MODELS: OLR400-A-HP | OLR500-A-HP | OLR600-A-HP

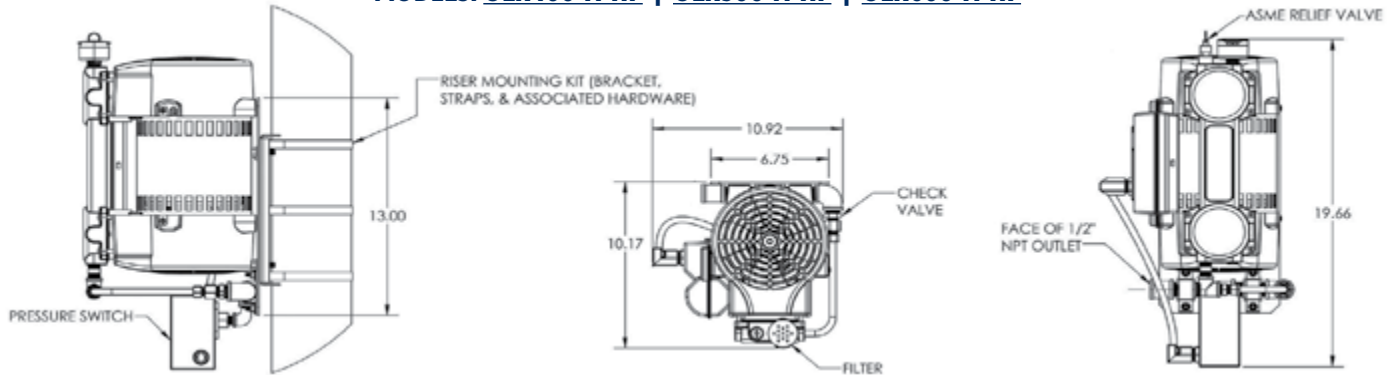

MODELS: OLR915-A-HP | OLR1100-A-HP

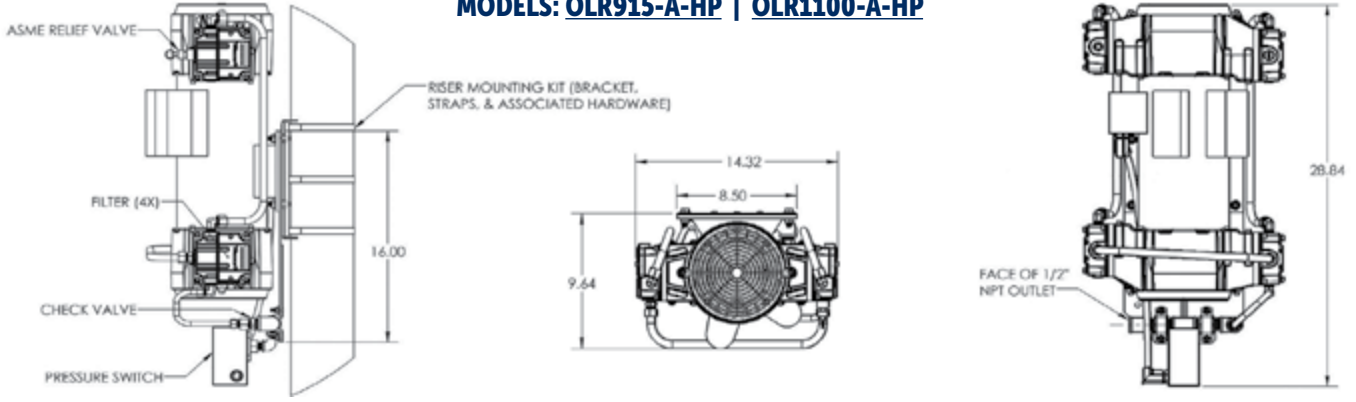

OL Plus Series High Pressure Riser Mount Fire Protection Air Compressors Accessories

VAPOR PIPE SHIELD



AIR MAINTENANCE DEVICE



The AMD-1 regulates the volume of air being delivered to the sprinkler system by the air compressor.

Per NFPA 13 - An Air Maintenance Device is required on every dry system unless the air compressor has a capacity less than 5.5 ft³/min at 10 PSI.

Part # AMD-1

MOTOR LINE STARTER



Thermal Overload Protection

MAX HP	SINGLE PHASE MOTOR LINE STARTERS			
	115V	208-230V	Size	Model
1/3 HP	1 HP	00	MG00A	
1 HP	2 HP	0	MGX0A	
2 HP	3 HP	1	MG01A	
3 HP	5 HP	1P	MG15A	

When Ordering a Motor Starter you must specify HP, Voltage & Phase.